

Effective 1 July 2021

# Special Regulations

Part 1 for Racing Boats



World Sailing



Australian Government  
Australian Sports Commission



**AUSTRALIAN SAILING  
SPECIAL REGULATIONS**

**PART 1**

**FOR RACING BOATS  
And  
Recommended for Cruising Boats**

Including Monohulls, Multihulls and Trailables

**These regulations came into effect in Australia from 1 July 2021.**

Any amendments or interpretations to what is published herein will be circulated to Clubs and will also be posted on the Australian Sailing website at

[www.sailingresources.org.au](http://www.sailingresources.org.au)

# DIAGRAMMATIC GUIDE

(see also alphabetical index)

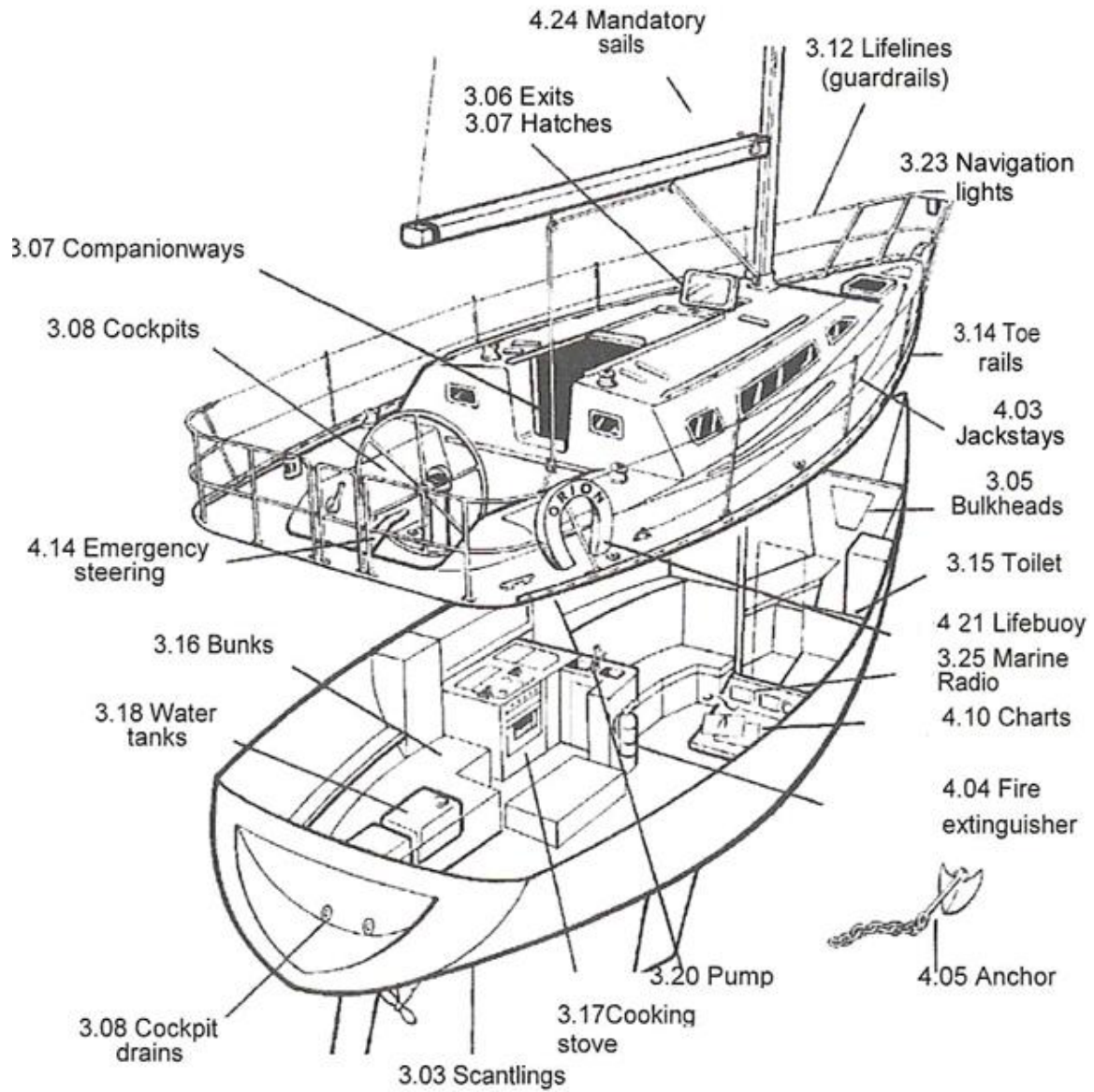

## CONTENTS

---

### **PART 1 SPECIAL REGULATIONS FOR RACING BOATS**

<b>1.</b>	<b><u>Fundamentals and Definitions</u></b>	<b>6</b>
1.01	<u>Purpose and Use</u>	6
1.02	<u>Responsibility of the Person In Charge</u>	7
1.03	<u>Definitions</u>	8
1.04	<u>Abbreviations</u>	10
<b>2.</b>	<b><u>Application and General Requirements</u></b>	<b>11</b>
2.01	<u>Categories of Events</u>	11
2.02	<u>Inspection and Monitoring</u>	12
2.03	<u>General Requirements</u>	13
2.04	<u>Crew Experience</u>	13
<b>3.</b>	<b>Part 1 <u>Structural Features, Stability</u></b>	<b>14</b>
3.01	<u>Strength of Build, Ballast and Rig</u>	14
3.02	<u>Watertight Integrity of Hull</u>	15
3.03	<u>Hull Construction Standards</u>	17
3.04	<u>Stability – Monohulls</u>	18
3.05	<u>Stability and Flotation – Multihulls</u>	18
	<b>Part 2 <u>Fixed Equipment</u></b>	<b>20</b>
3.06	<u>Exits</u>	20
3.07	<u>Hatches and Companionways</u>	22
3.08	<u>Cockpits</u>	23
3.09	<u>Seacocks</u>	25
3.10	<u>Sheet Winches</u>	25
3.11	<u>Mast Step</u>	25
3.12	<u>Pulpits, Stanchions, Lifelines</u>	25
3.13	<u>Multihull Nets or Trampolines</u>	29
3.14	<u>Toe Rail or Foot-Stop</u>	31
3.15	<u>Toilet</u>	31
3.16	<u>Bunks</u>	31
3.17	<u>Galley</u>	31
3.18	<u>Water Tanks and Water</u>	32
3.19	<u>Hand Holds</u>	32
3.20	<u>Bilge Pumps and Buckets</u>	33
3.21	<u>Compass</u>	33
3.22	<u>Halyards</u>	34

3.23	<a href="#">Navigation Lights</a>	34
3.24	<a href="#">Engines, Generators, Fuel</a>	34
3.25	<a href="#">Marine Radio</a>	36
3.26	<a href="#">Batteries</a>	38
3.27	<a href="#">Barometer</a>	39
3.28	<a href="#">Hull Identification</a>	39
3.29	<a href="#">Automatic Identification System (AIS)</a>	39
<b>4.</b>	<b><a href="#">Portable Equipment and Supplies</a></b>	<b>40</b>
4.01	<a href="#">Sail Numbers</a>	40
4.02	<a href="#">Plugs</a>	40
4.03	<a href="#">Jackstays, Clipping Points and Static Safety Lines</a>	40
4.04	<a href="#">Fire Extinguishers</a>	41
4.05	<a href="#">Anchors</a>	42
4.06	<a href="#">Spotlights and Flashlights</a>	44
4.07	<a href="#">Medical Kit and Manual</a>	44
4.08	<a href="#">Foghorn</a>	50
4.09	<a href="#">Intentionally Spare</a>	50
4.10	<a href="#">Charts, Piloting Equipment and Books</a>	51
4.11	<a href="#">GPS</a>	51
4.12	<a href="#">Depth Sounder</a>	51
4.13	<a href="#">Log</a>	51
4.14	<a href="#">Emergency Steering</a>	51
4.15	<a href="#">Tools and Spare Parts</a>	52
4.16	<a href="#">Boat's Name</a>	52
4.17	<a href="#">Retroreflective Tape</a>	52
4.18	<a href="#">EPIRBs</a>	52
4.19	<a href="#">Liferafts</a>	53
4.20	<a href="#">Grab Bags to Accompany Liferafts</a>	55
4.21	<a href="#">Lifebuoys</a>	56
4.22	<a href="#">Pyrotechnics (Flares)</a>	57
4.23	<a href="#">Heaving Line</a>	58
4.24	<a href="#">Storm and Heavy Weather Sails</a>	58
4.25	<a href="#">Drogue, Sea Anchor</a>	59
4.26	<a href="#">Retrieval of Crew from the Water</a>	60
4.27	<a href="#">Distress Sheet</a>	60
4.28	<a href="#">Stowage Chart</a>	60
<b>5.</b>	<b><a href="#">Personal Equipment</a></b>	<b>61</b>
5.01	<a href="#">Lifejackets</a>	61
5.02	<a href="#">Safety Harnesses and Safety Lines (Tethers)</a>	62

5.03	<a href="#">Personal Lights</a>	64
5.04	<a href="#">Personal Clothing</a>	64
5.05	<a href="#">Personal Locator Beacon</a>	64
<b>6.</b>	<b><a href="#">Training</a></b>	<b>66</b>
6.01	<a href="#">Training</a>	66
<b>7.</b>	<b><a href="#">Appendices Referenced in Special Regulations</a></b>	<b>68</b>
Appendix A	<a href="#">Equipment for USL Coastal Liferrafts</a>	68
Appendix B	<a href="#">Resistance to Capsize for Monohulls</a>	70
Appendix C	<a href="#">Model Keel and Rudder Inspection</a>	78
<b>8.</b>	<b><a href="#">Advisory Appendices</a></b>	<b>80</b>
Appendix D	<a href="#">Man Overboard – Quick Stop and the Lifesling</a>	80
Appendix E	<a href="#">Hypothermia</a>	86
Appendix F	<a href="#">Drogues and Sea Anchors</a>	91
Appendix G	<a href="#">Pain Chart</a>	93



## SECTION 1 - FUNDAMENTALS AND DEFINITIONS

---

### 1.01 PURPOSE AND USE

**1.01.1** The purpose of these Special Regulations is to establish uniform minimum equipment, accommodation and training standards for racing boats and as a guide for cruising boats.

**1.01.2** These Special Regulations do not replace, but rather supplement, the requirements of governmental authority, the Racing Rules of Sailing and the rules of class associations and rating systems.

#### 1.01.3

**(a)** Notwithstanding clause [1.01.2](#), every boat shall comply as a minimum with these Special Regulations of Australian Sailing for the nominated category of race. The organising authority shall select the category deemed most suitable for the type of race to be sailed.

**(b)** These regulations shall not be varied except with the written approval of Australian Sailing.

**(c)** Where a variation is approved for an event, the wording of the approval shall be included in the notice of race for the event.

**(d)** An organising authority that is conducting a cruising event may:

- develop its own safety guide to cruising
- vary the Special Regulations at its discretion by stipulating alternative requirements that are appropriate for the event's circumstances.
- use compliance with the Special Regulations for a nominated race category

#### 1.01.4

**(a)** In the regulations a number indicates the category of race for which the item is mandatory. The letter "N" indicates that the item is mandatory for night sailing.

**(b)** The use of the feminine or masculine gender shall be taken to mean either gender.

**1.01.5** Official interpretations of these Special Regulations issued by Australian Sailing shall be considered to be part of the regulations and will be dated and displayed on the Australian Sailing website [www.sailingresources.org.au](http://www.sailingresources.org.au)

## **1.02 RESPONSIBILITY OF THE PERSON IN CHARGE**

**1.02.1** The safety of a boat and her crew is the sole and inescapable responsibility of the person in charge who shall do their best to ensure that the boat is fully found, thoroughly seaworthy and manned by an experienced crew who have undergone appropriate training and are physically fit to face bad weather. He must be satisfied as to the soundness of hull, spars, rigging, sails and all gear. He shall ensure that all safety equipment is properly maintained and stowed and that the crew know where it is kept and how it is to be used. Attention is drawn to Regulation [2.04](#) that specifies the crew experience required for some races. He shall also nominate a person to take over the responsibilities of the person in charge in the event of his incapacitation.

**1.02.2** The establishment of these Special Regulations, their use by race organisers, and the inspection of a boat under these regulations does not in any way limit or reduce the complete and unlimited responsibility of the person in charge.

**1.02.3** The responsibility for a boat's decision to participate in a cruising event or race, or to continue racing is hers alone - RRS Fundamental Rule 4.



### 1.03 DEFINITIONS

<b>1.03.1 Age Date</b>	Month / Year of first launch.
<b>Buoyancy</b>	Shall be achieved by the use of: <ul style="list-style-type: none"><li>(i) Semi-rigid or rigid non-absorbent material permanently fixed into the hull;</li><li>(ii) Dedicated, empty, sealed compartments which may be fitted with screw-in drain plugs or an inspection port but which shall remain closed whilst racing;</li><li>(iii) Inflated airbags, permanently sealed and fixed below decks.</li></ul> Buoyancy shall be so distributed as to float the boat evenly when swamped including in the capsized position.
<b>Cruising Event</b>	Covers a wide range of activities from a group of yachts conducting a passage in loose or close company to some form of competition outside the restrictions of the RRS and a strict interpretation of these regulations.
<b>Effective Rescue Availability</b>	Requires the race committee to have in place an effective rescue procedure taking into account the local conditions, length of race, remoteness, availability of rescue craft and services, and the quality of communications.
<b>FA Station</b>	The transverse station at which the upper corner of the transom meets the sheerline.
<b>LH</b>	Hull length as defined by the Equipment Rules of Sailing.
<b>Lifeline</b>	Wire rigged as a guardrail around the deck.
<b>LWL</b>	Loaded Waterline Length.
<b>Maximum Beam</b>	The maximum beam of the boat.
<b>Monohull</b>	Hull in which the hull depth in any section does not decrease towards the centreline. All other boats are considered to be multihulls.
<b>Movable Ballast</b>	Lead or other material including water which has no practical function in the boat other than to increase

	weight and/or to influence stability and/or trim and which may be moved transversely but not varied in weight while a boat is racing.
<b>Notified Body</b>	Bodies authorised under the Recreational Craft Directive, European Commission or International Organization for Standardization to approve construction standards of yachts.
<b>Permanently Installed</b>	Means the item is effectively built-in by bolting, welding, glassing etc. and may not be removed while racing.
<b>Primary Launch</b>	Month and year of first launch of the first boat of the production series or first launch of a non-series boat.
<b>Protected Waters</b>	Are those not fully exposed to the extremes of the ocean in such a way that the ocean swell has been broken. It may include large bays and gulfs.
<b>Securely Fastened</b>	Held strongly in place by a method (e.g. rope lashings, wing-nuts) which will safely retain the fastened object in severe conditions including a 180 degree capsize and allows for the item to be removed and replaced during racing.
<b>Series Date</b>	Month / Year of the launch of the first boat of a production series.
<b>Sheltered Waters</b>	Are those sheltered from the extremes of the sea by reefs, headlands or islands. This would infer that the ocean swell has been broken and that there is limited fetch. It can include harbours, estuaries and lakes.
<b>Static Ballast</b>	Lead or other material including water which has no practical function in the boat other than to increase weight and/or to influence stability and/or trim and which may not be moved or varied in weight while a boat is racing.
<b>Trailable Boat</b>	For the purpose of these regulations a trailable boat is a monohull ballasted boat, or a multihull which can be transported on the public road system on the same trailer used to launch and retrieve it without the assistance of external equipment or detachment from the towing vehicle.
<b>Unprotected Waters</b>	Are those which are directly exposed to the extremes of the ocean.

**Variable Ballast** Water carried for the sole purpose of influencing stability and/or trim and which may be varied in weight and/or moved while a boat is racing.

**Working Deck** Shall be deemed to be any surface on which the crew might stand in order to handle the boat and its sails in a seamanlike manner.

**1.03.2** “Shall” and “must” are mandatory; “should” and “may” are permissive.

## **1.04 ABBREVIATIONS**

<b>ABS</b>	American Bureau of Shipping
<b>AIS</b>	Automatic Identification System
<b>AMSA</b>	Australian Maritime Safety Authority
<b>AS</b>	Standards Australia
<b>CE</b>	Mark of European Commission
<b>DSC</b>	Digital Selective Calling
<b>EC</b>	European Commission
<b>EN</b>	European Norm (Carries CE symbol)
<b>EPFS</b>	Electronic Position Fixing System
<b>ERS</b>	Current Equipment Rules of Sailing
<b>GMDSS</b>	Global Maritime Distress and Safety System
<b>GPS</b>	Global Positioning System
<b>HMPE</b>	High-Modulus Polyethylene
<b>IRC</b>	International Rule – Club
<b>ISAF</b>	World Sailing (International Sailing Federation)
<b>ISO</b>	International Organization for Standardization
<b>MMSI</b>	Maritime Mobile Service Identifier
<b>MOB</b>	Man Overboard
<b>MYA</b>	Member Yachting Association of Australian Sailing
<b>ORCi</b>	ORC International Measurement System
<b>RNLI</b>	Royal National Lifeboat Institute
<b>RRS</b>	Current Racing Rules of Sailing
<b>SAR</b>	Search and Rescue
<b>SOLAS</b>	International Convention for Safety of Life at Sea
<b>USL</b>	Uniform Shipping Laws

### 2.01 CATEGORIES OF EVENTS

As there are many types of racing events, ranging from long distance ocean races sailed under adverse conditions to short course day races sailed in protected or sheltered waters, seven categories of races have been established as follows, to provide for the differences in the standards of equipment and accommodation required for such varying circumstances:

Categories 0-4 are intended for offshore racing.

Categories 5 and 6 are suitable for (but not exclusive to) races which include only trailable boats.

An organising authority shall select the category most suitable for the type of race to be sailed, the locale that it is to be sailed in and the conditions under which it is to be sailed. An organising authority may add to the requirements of a particular category but not delete any.

- 2.01.1 Category 0:** Trans-oceanic races, including races which pass through areas in which air or sea temperatures are likely to be less than 5 degrees Celsius other than temporarily, where boats must be completely self-sufficient for very extended periods of time, capable of withstanding heavy storms and prepared to meet serious emergencies without the expectation of outside assistance. Specific requirements for Category 0 have been omitted from this version.

- 2.01.2 Category 1:** Offshore races of long distance and well offshore, where boats must be self-sufficient for extended periods of time, capable of withstanding heavy storms and prepared to meet serious emergencies without the expectation of outside assistance.
- 2.01.3 Category 2:** Offshore races of extended duration along or not far removed from shorelines or in large unprotected bays or lakes, where a high degree of self-sufficiency is required of the yachts.
- 2.01.4 Category 3:** Offshore races across open water, most of which is relatively protected or close to shorelines.
- 2.01.5 Category 4:** Short offshore races, close to shore in relatively warm or protected waters, normally held in daylight.
- 2.01.6 Category 5:** Races with limited rescue availability, in protected waters, in daylight hours or in sheltered waters at night.
- 2.01.7 Category 6:** Short races close to the shoreline in protected waters, in daylight hours only and with effective rescue availability.
- 2.01.8 Category 7:** Short races in sheltered waters, in daylight hours only and with effective rescue availability. Boats not complying with [3.01.3](#) are not required to carry buoyancy.

## **2.02 INSPECTION AND MONITORING**

- 2.02.1** For the purposes of inspection under these regulations an MYA may accredit Equipment Auditors.
- 2.02.2** A boat may be inspected at any time and shall demonstrate compliance with these regulations. The boat's club or the race committee of an event may appoint an accredited Equipment Auditor or other person to conduct inspections of the equipment required by Regulation [2.03](#), [Section 3 Part 2](#), [Sections 4](#) and [5](#) of these regulations.
- 2.02.3** If a boat does not comply with these Special Regulations, it may have its entry rejected by the organising authority, or it may be liable to disqualification or such other penalty determined by the protest committee.
- 2.02.4** A race committee shall arrange for constant radio monitoring of the nominated race frequency/ies while any race is in progress and for a reasonable period prior to and after the race. Details shall be provided in the sailing instructions.
- 2.02.5** The Organising Authority of a race will establish whether any incidents occurred, which if reported would be likely to be relevant to evolving the

Special Regulations, the plan review process, or in increasing safety. The Organising Authority will follow any guidelines issued by Australian Sailing and World Sailing concerning incident reporting.

**In the following list a number indicates that the item is a mandatory requirement for that category and the letter “N” indicates that the item is mandatory for night sailing. Items in italics are recommendations.**

		RACE CATEGORY						
<b>2.03</b>	<b>GENERAL REQUIREMENTS</b>							
<b>2.03.1</b>	All equipment required by these Special Regulations shall:	1	2	3	4	5	6	7
(a)	Function properly.							
(b)	Be regularly checked, cleaned and serviced.							
(c)	When not in use be stowed in conditions in which deterioration is minimised.							
(d)	Be readily accessible.							
(e)	Be of a type, size and capacity suitable and adequate for the intended use and size of the boat.							
<b>2.03.2</b>	Heavy Items:	1	2	3	4	5	6	7
(a)	Ballast, tanks, ballast tanks and associated equipment shall be permanently installed.							
(b)	Heavy movable items including batteries, stoves, gas bottles, toolboxes, and anchors and chain shall be securely fastened.							
(c)	Heavy items for which fixing is not specified in these Special Regulations shall be permanently installed or securely fastened, as appropriate.							
<b>2.04</b>	<b>CREW EXPERIENCE</b>							
	The number of crew specified below, including the skipper and/or person in charge shall have completed one race of the category entered or an equivalent passage. Evidence of such shall be provided if requested by the race committee.							
<b>2.04.1</b>	At least half the crew.	1	2					
<b>2.04.2</b>	At least 2 crew members.			3				



SECTION 3 – PART 1 STRUCTURAL FEATURES, STABILITY

RACE  
CATEGORY

**3.01 STRENGTH OF BUILD, BALLAST AND RIG**

<b>3.01.1</b>	A boat shall be soundly constructed, well maintained and suitable for the event it will be entering. Hulls shall be watertight and, particularly with regard to hulls, decks and cabin trunks, capable of withstanding solid water and knockdowns. It must be properly rigged and ballasted, be fully seaworthy and must meet the standards set forth herein. Including Monohulls, Multihulls and Trailables ..... 1 SECTION 1 - FUNDAMENTALS AND DEFINITIONS ..6 AS ..... 10 SECTION 2 - APPLICATION AND GENERAL REQUIREMENTS ..... 11 SECTION 3 – PART 1 STRUCTURAL FEATURES, STABILITY ..... 14 SECTION 3 – PART 2 FIXED EQUIPMENT .....20 SECTION 4 - PORTABLE EQUIPMENT AND SUPPLIES.....40 FOR ALLERGY .....50 SECTION 5 - PERSONAL EQUIPMENT .....61 SECTION 6 – TRAINING.....66 AUSTRALIAN SAILING SPECIAL REGULATIONS70 AUSTRALIAN SAILING SPECIAL REGULATIONS78 SEA ANCHORS ON YACHTS.....92 Shrouds shall never be disconnected.	1	2	3	4	5	6
<b>3.01.2</b>	Trailable boats with an age date prior to 07/2001, when competing in races for trailable boats only, that do not comply with <a href="#">3.04 (Stability)</a> or with <a href="#">3.08 (Cockpits)</a> shall have sufficient buoyancy to support the boat, its crew and stores above the water when fully swamped.						5
<b>3.01.3</b>	All boats that do not comply with <a href="#">3.04 (Stability)</a> or with <a href="#">3.08 (Cockpits)</a> shall have sufficient buoyancy to support the boat, its crew and stores above the water when fully swamped.						6
<b>3.01.4</b>							

SECTION 3 – PART 1 STRUCTURAL FEATURES, STABILITY

(a) A boat shall be soundly constructed, well maintained and suitable for the event that it will be entering. It must be properly rigged, and must meet the standards set forth herein. 7

(b) Boats that are not resistant to capsize or buoyant or do not comply with [3.08 \(Cockpits\)](#) are restricted to sheltered waters and the race committee must ensure that there is effective rescue capability available. 7

**3.01.5 Ballast Tanks, Valves and Sea Cocks** 1 2 3 4 5 6 7

Tanks for variable ballast shall be permanently installed to a boat's structure and shall be provided with a system of isolating valves and pump(s) capable of manual operation at any angle of heel. A plan of the plumbing system shall be displayed aboard the boat.

**3.01.6 Control Systems, Actuators, Restraint** 1 2 3 4 5 6 7

Movable ballast systems shall be fitted with a manual control and actuation secondary system which shall be capable of controlling the keel in the event of failure of the primary system. Such failures could include electrical and hydraulic failure and mechanical failure of the components and the structure to which the primary system is mounted. The system must be capable of being operational quickly and shall be operable at any angle of heel. It would be desirable if this system was capable of securing the keel on the centreline.

A set of instructions, including any necessary diagrams, for the activation and operation of the secondary system shall be displayed aboard the boat.

**3.02 WATERTIGHT INTEGRITY OF HULL**

**3.02.1** A hull, including, deck, coach roof, windows, ports, hatches and all other parts, shall form an integral, essentially watertight unit and any openings in it shall be capable of being immediately secured to maintain this integrity. 1 2 3 4 5 6

**3.02.2**

SECTION 3 – PART 1 STRUCTURAL FEATURES, STABILITY

- (a) Centreboard and daggerboard trunks and the like shall not open into the interior of a hull except via a watertight inspection/maintenance hatch of which the opening shall be entirely above the waterline of the yacht floating level in normal trim. 1 2 3 4
  - (b) Canting keels and the like, together with any control mechanism, shall be constructed in such a way that the watertight integrity of the hull is not compromised. 1 2 3 4 5 6 7
  - (c) Centreboard and daggerboard trunks and the like shall either not open into the interior of the hull or shall be fitted with some device that effectively limits ingress of water to the interior of the hull with the keel/ centreboard in any position. 5 6
- 3.02.3**
- (a) Boats with movable keels or centreboards shall have a positive non friction device which will prevent the keel or centreboard from moving in the event of a knockdown or capsize. The keel or centreboard shall always be locked in position except whilst being moved from one position to another (except that boats which have a shallow ballasted keel, or which have internal fixed ballast with either a swing or drop keel lowered through a sealed case, are exempt from the lock down device provided at least 80% of the ballast is in the fixed keel or hull). 1 2 3 4 5 6
  - (b) Where a boat is required to have the keel or centreboard at a specific position to comply with the resistant to capsize requirements of these regulations, then it shall not be moved to a higher position. 1 2 3 4 5 6
  - (c) Boats not complying with [3.04.1](#) and [3.04.2](#) (stability) shall not lift centreboards or keels whilst racing. 5 6
- 3.02.4** Effective 1 January 2022: Structural Inspection – Consult the owner’s manual for any instructions for keel bolt checking and re-tightening. The following inspection to be conducted by a qualified person externally with the boat out of the water. Check that there are no visible stress cracks particularly around the keel, hull/keel attachment, hull appendages and other stress points, inside the hull, backing plates, bolting arrangements and keel floors. (See [Appendix C – Model Keel and Rudder Inspection Procedure](#)) 1 2 3

SECTION 3 – PART 1 STRUCTURAL FEATURES, STABILITY

**3.02.5** Effective 1 January 2022: Evidence of a structural inspection in accordance with 3.02.4 within 24 months before the start of the race or after a grounding whichever is the later. 1 2 3

**3.02.6** Effective 1 January 2022: Inspection after Grounding – an appropriately qualified person shall conduct an internal and external inspection after each unintentional grounding. 1 2 3

**3.03 HULL CONSTRUCTION STANDARDS (Scantlings)**

**3.03.1** A monohull with an age or series date after 1 July 2010:

**(a)** Of less than 24 m in hull length (measured in accordance with ISO 8666) shall have: 1 2

- Been designed, built and maintained in accordance with the requirements of ISO 12215 Category A.
- On board a certificate of building plan review from a notified body recognised by World Sailing.

**(b)** Of 24 m in hull length and over (measured in accordance with ISO 8666) shall have: 1 2

- Been designed, built and maintained in accordance with requirements of a Classification Society recognised by World Sailing.
- On board a certificate of building plan review certificate issued from a a Classification Society recognised by World Sailing.

**(c)** On board a declaration signed and dated by the builder to confirm the yacht is built in accordance with the reviewed plans. In cases a builder no longer exists, a race organiser or class rules may accept a signed statement of above in lieu of the Builder’s Declaration, and 1 2

**(d)** Have an additional World Sailing certificate of building plan review in accordance with (a) or (b) and (c) above for any significant repair or modification to the hull, deck, coachroof, keel or appendages. 1 2

**3.03.2** A monohull with Primary Launch between 1987 and 1 July 2010 shall have been designed, built, maintained, modified or repaired in accordance with the requirements of:

**(a)** [3.03.1](#), or 1 2

- (b) the ABS Guide for Building and Classing Offshore Yachts and have on board either an ABS certificate of plan approval, or written statements signed by the designer and builder confirming that they have respectively designed and built the boat in accordance with the ABS Guide, or 1 2
- (c) the EC Recreational Craft Directive for Category A having obtained the CE mark, or 1 2
- (d) ISO 12215 Category A, with written statements signed by the designer and builder confirming that they have respectively designed and built the boat in accordance with the ISO standard, and 1 2
- (e) have written statements or approvals in accordance with (a), or (b) or (c) and (d) above for all significant repairs or modifications to the hull, deck, coach roof, keel or appendages, on board, except 1 2
- (f) that a race organizer or class rules may accept, when that described in (a), (b), (c), (d) or (e) above is not available, the signed statement by a naval architect or other person familiar with the standards listed above that the boat fulfils these requirements 1 2

**3.04 STABILITY – MONOHULLS**

- 3.04.1 Australian Sailing requires a yacht to comply with a minimum stability or stability index as set out in [Appendix B](#). 1 2 3 4 5 6
- 3.04.2 A yacht shall be resistant to capsize and shall have a ballasted keel, internal ballast or ballasted centreboard. 7
- 3.04.3 Compliance with [Appendix B](#) does not guarantee that a boat will, in fact, resist capsize or self-right in all conditions encountered at sea. 1 2 3 4 5 6

**3.05 STABILITY AND FLOTATION – MULTIHULLS**

- 3.05.1 Adequate watertight bulkheads and compartments (which may include permanently installed flotation material) in each hull shall be provided to ensure that a multihull is effectively unsinkable and capable of floating 1 2 3 4

SECTION 3 – PART 1 STRUCTURAL FEATURES, STABILITY

- in a stable position with at least half the length of one hull flooded.
- 3.05.2** Multihulls first launched on or after 07/2005 shall in every hull without accommodation be divided at intervals of not more than 4 m by one or more transverse watertight bulkheads. 1 2 3 4
- 3.05.3** Any required watertight bulkhead shall be strongly built to take a full head of water pressure without allowing any leakage into the adjacent compartment. 1 2 3 4
- 3.05.4** A hull shall have a watertight “crash” or “collision” bulkhead either: 1 2 3 4
- (a)** Within 15% of LH from the bow and abaft the forward end of LWL;  
OR 1 2 3 4
- (b)** Between 5% and 15% of LWL behind the forward end of LWL (This watertight compartment shall be divided horizontally by a bulkhead above the waterline  
OR 1 2 3 4
- (c)** Permanently installed closed-cell foam buoyancy effectively filling the forward 30% LH of the hull. 1 2 3 4



**3.06 EXITS****3.06.1 MONOHULLS**

- (a) (i) Boats 8.5 m LH and longer with an Age or Series Date of 01/1995 or later shall have two exits. One exit shall be located forward of the foremost mast. 1 2 3 4
- (ii) In very unusual circumstances (such as in a cat rigged boat) where structural features prevent its installation forward of the mast, an alternative location may be approved upon application to Australian Sailing provided the dimensions in [3.06.1 \(c\)](#) or [\(d\)](#) are complied with.
- (b) Boats 5.5 m LH and longer of any Age Date and with enclosed cabins which carry any liquid fuel or gas below decks while racing shall have two exits as in [3.06.1\(a\)](#). 1 2 3 4 5 6 7
- (c) For boats with an Age or Series Date of 07/2010 or later the minimum clearance diameter through an exit hatch shall be 450 mm. 1 2 3 4
- (d) Yachts with an Age date on or after 07/2014 shall have an exit hatch with the following minimum clear openings in compliance with ISO 9094: 1 2 3 4
- (i) Circular shape diameter 450 mm, or
- (ii) Any other shape minimum dimension of 380 mm and minimum area of 0.18 m<sup>2</sup>. The dimensions must be large enough to allow for a 380 mm diameter circle to be inscribed.

**3.06.2 MULTIHULLS**

- 3.06.3** Each hull which contains accommodation shall have at least two exits. 1 2 3 4
- 3.06.4** Multihulls of 12 m LH and greater in each hull which contains accommodation shall have: 1 2 3 4
- (a) An escape hatch for access to and from the hull in the event of an inversion.
- (b) For boats with an Age or Series Date of 07/2010 or later the minimum clearance diameter through an exit hatch shall be 450 mm.

- (c) In a multihull first launched on or after 01/2003 each escape hatch shall comply with [3.06.4\(b\)](#).
  - (d) When the multihull is inverted each escape hatch shall be above the waterline.
  - (e) In a multihull first launched on or after 01/2001 each escape hatch shall be at or near the midships station.
  - (f) In a catamaran first launched on or after 01/2003 each escape hatch shall be on the side of a hull nearest the centreline of the boat.
  - (g) A catamaran first launched on or after 01/2003 with a central nacelle shall have on the underside of the boat around the central nacelle, handholds of sufficient capacity to enable all persons on board to hold on and/or clip on securely.
  - (h) *It is recommended that in a catamaran with a central nacelle, each hull should have an emergency refuge, accessible via a special hatch in the side of the hull nearest the central nacelle, which hatch may be opened and closed from the inside and outside.*
  - (i) A trimaran of 12 m LH and greater first launched on or after 01/2003 shall have at least two escape hatches in accordance with [3.06.4\(b\)](#).
  - (j) A trimaran shall have on the underside of the boat around the central hull, handholds of sufficient capacity to enable all persons on board to hold on and/or clip on securely.
  - (k) Each escape hatch must have been opened both from inside and outside within six months prior to an intended race.
- 3.06.5** Multihulls less than 12 m LH with an Age Date of 07/2006 or later shall comply with [3.06.4\(b\)](#). *Prior to that date it is strongly recommended that they do so and they shall comply with the following as a minimum:*
- (a) Each hull which contains accommodation shall have, for the purpose of cutting an escape hatch, appropriate tools kept ready for instant use adjacent to the intended cutting site. Each tool shall be secured to the vessel by a line and a clip and;

2 3 4

- (b) In each hull at a station where an emergency hatch may be cut, the cutting line shall be clearly marked both inside and outside with an outline and the words “**ESCAPE CUT HERE**”.

**3.07 HATCHES AND COMPANIONWAYS**

**3.07.1** No hatch, window or port forward of the maximum beam station shall have a lid or cover that opens inwards, except ports with an area less than 0.071 m<sup>2</sup>. 1 2 3 4 5 6

**3.07.2**

(a) (i) A hatch or port shall be so arranged as to be above the water when the hull is heeled 90 degrees. Hatches over lockers that open to the interior of the vessel shall be included in this requirement. 1 2 3 4 5 6

(ii) A yacht may have a maximum of four (two on each side of the centreline) hatches or ports that do not conform to requirement [3.07.2 \(a\)\(i\)](#), provided that the opening of each is less than 0.071 m<sup>2</sup> and each hatch is kept firmly shut while racing. 1 2

(iii) A yacht may have hatches or ports that do not conform to the requirement of [3.07.2\(a\)\(i\)](#), provided that the opening of each is less than 0.071 m<sup>2</sup> and each hatch is kept firmly shut while racing. 3 4 5 6

(b) A hatch or port shall be capable of being firmly shut immediately by a permanently attached lid or cover and remaining firmly shut in a 180 degree capsizes. Companionway washboards are excepted. 1 2 3 4 5

**3.07.3** Hatches, windows or ports not conforming with 3.07.1 and 3.07.2 are permitted if clearly labelled and used in accordance with the following instruction “NOT TO BE OPENED AT SEA”. 1 2 3 4 5 6

**3.07.4** A companionway hatch extending below the local sheerline, shall be capable of being strongly and rigidly secured so the companionway hatch is blocked off up to the level of the local sheerline. The companionway hatch 1 2 3 4 5

shall continue to give access to the interior with these temporary blocking devices (e.g. washboards) in place.

**3.07.4**

- (a)** A companionway hatch shall be fitted with a strong securing arrangement (e.g. latch), capable of securing the hatch in a closed position, which shall:
  - (i) Be operable from above and below including when the boat is inverted. 1 2 3 4 5
  - (ii) Function independently of any blocking devices. 1 2 3
- (b)** A companionway hatch shall have any blocking devices (e.g. washboards):
  - (i) Capable of being retained in position with the hatch open or shut. 1 2 3 4 5
  - (ii) Secured to the boat (e.g. by lanyard) for the duration of the race to prevent being lost overboard.
  - (iii) So positioned as to permit exit in the event of an inversion.

**3.08 COCKPITS**

- 3.08.1** Cockpits shall be structurally strong, self-draining quickly by gravity at all angles of heel and permanently incorporated as an integral part of the hull. 1 2 3 4 5 6
- 3.08.2** Cockpits shall be essentially watertight, that is, all openings to the hull must be capable of being strongly and rigidly secured. 1 2 3 4 5 6
- 3.08.3** A bilge pump outlet pipe or pipes shall not be connected to a cockpit drain. See [3.08.7](#) for cockpit drain minimum sizes. 1 2 3 4 5 6
- 3.08.4** A cockpit sole shall be at least 2% LWL above LWL. 1 2 3 4 5 6
- 3.08.5** A bow, lateral, central or stern well shall be considered a cockpit for the purposes of [3.08](#). 1 2 3 4 5 6

**3.08.6 Cockpit Volume**

	<b>Earliest of Age or Series Date</b>	<b>Detail</b>	
<b>(a)</b>	Before 04/1992	The total volume of all cockpits below lowest coamings shall not exceed 6%	1

		LWL x maximum beam x freeboard abreast the cockpit.	
<b>(b)</b>	Before 04/1992	The total volume of all cockpits below lowest coamings shall not exceed 9% LWL x maximum beam x freeboard abreast the cockpit.	2 3 4
<b>(c)</b>	04/1992 and after	(a) or (b) above applies except that the lowest coamings shall not include any coaming aft of the FA station and no extension of a cockpit aft of the working deck shall be included in the calculation.	1 2 3 4
<b>(d)</b>	01/2003 and after	Calculations shall be based on LWL, maximum beam, and freeboard abreast the cockpit.	1 2 3 4

<b>NOTE:</b>	For multihulls, LWL is the Length Overall; freeboard abreast the cockpit is the freeboard at the lowest cockpit coaming; maximum beam is the sum of the maximum beams of all the hulls. Hull beams shall be measured at working deck level amidships.	1 2 3 4
--------------	---	---------

**3.08.7 Cockpit Drains – MONOHULLS**

LH	Earliest of Age or Series Date	Minimum draining size after allowance for screens	
Under 8.5 m	Any	2 x 25 mm diameter or equivalent	1 2 3 4 5 6
8.5 m and over	before 07/1977	2 x 25 mm diameter or equivalent	1 2 3 4 5 6
8.5 m and over	after 07/1977	4 x 20 mm diameter or equivalent	1 2 3 4 5 6

**3.08.8 Cockpit Drains - MULTIHULLS**

The minimum drain sizes after allowance for screens shall be 20 cm<sup>2</sup> per m<sup>3</sup> of cockpit. 1 2 3 4 5 6 7

**3.09 SEACOCKS**

**3.09.1**

**(a)** Seacocks or valves shall be permanently installed on all through hull openings below LWL except propeller shaft log, speed indicators, depth finders and the like; however, a means of closing such openings, shall be provided. 1 2 3 4 5

**(b)** Each through hull opening except for propeller shaft log shall have a soft wood or rubber plug, tapered and of the appropriate size attached to or stowed near it. Plugs shall be of sufficient size to cater for failure of the complete fitting where it attaches to the hull. 1 2 3 4 5

**3.10 SHEET WINCHES**

Sheet winches shall be mounted in such a way that an operator is not required to be substantially below deck. 1 2 3 4 5

**3.11 MAST STEP**

The heel of a keel stepped mast shall be securely fastened to the mast step or adjoining structure. 1 2 3 4

**3.12 PULPITS, STANCHIONS, LIFELINES**

*Boats shall be equipped with a system of lifelines and/or guardrails designed to form an effectively continuous barrier around a working deck and complying with the requirements of this section with the aim of minimising the risk of people falling overboard.*

**3.12.1** When the particular design of a multihull makes it impractical to precisely follow Special Regulations regarding pulpits, stanchions and lifelines, the regulations for monohulls shall be followed as closely as possible with the aim of minimising the risk of people falling overboard. 1 2 3 4

**(a)** Where lifelines are not fitted to a multihull at all, or when on areas of deck that are not protected by an effective lifeline system, crew shall be required to wear a harness and be attached to the boat between the hours of sunset and sunrise. 1 2 3



- (b)** Where lifelines are not fitted to a multihull at all, or when on areas of deck that are not protected by an effective lifeline system, crew are strongly recommended to wear a harness and be attached to the boat at times such as, but not limited to:

1 2 3

- (i) When alone on deck
- (ii) When the true wind speed is 25 knots or above
- (iii) When visibility is less than 1 nautical mile

*As an indication, when a deflecting force of 50 N is applied to a lifeline midway between supports, the lifeline should not deflect more than 50 mm.*

**3.12.3** The following shall be provided:

- (a)** A bow pulpit with vertical height and openings essentially conforming to [3.12.5](#) and

1 2 3 4

- (i) A closed pulpit shall be forward of the forestay.
- (ii) The forward gap in an open pulpit shall not exceed 360 mm, or
- (iii) A bow pulpit may be open provided the opening between the pulpit and any part of the boat does not exceed 360 mm.

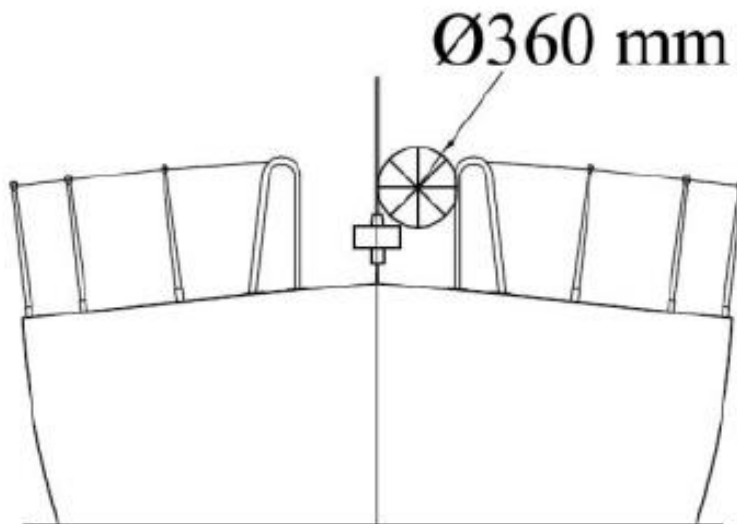

- (iv) May be a post pulpit providing adequate termination for the lifelines. Attention is drawn to ISO 15085.

- (b)** A stern pulpit or lifelines arranged as an adequate substitute, with vertical openings conforming to [3.12.5](#). Upper rails of pulpits shall be at no less height above the working deck or cockpit floor than upper lifelines, which height shall be essentially the same above the waterline

1 2 3 4

- as is that of the upper lifeline abreast the forward part of the cockpit with the aim of minimising the risk of people falling overboard.
- (c) Lifelines (guardlines) supported on stanchions, which, with pulpits, shall form an effectively continuous barrier around a working deck with the aim of minimising the risk of people falling overboard. Lifelines shall be permanently supported at intervals of not more than 2.20 m and shall not pass outboard of supporting stanchions. 1 2 3 4
- (d) Upper rails of pulpits shall be at no less height above the working deck than the upper lifelines as in [3.12.5](#). 1 2 3 4 5
- (e) Openable upper rails in bow pulpits shall be secured shut whilst racing. 1 2 3 4 5
- (f) Pulpits and stanchions shall be permanently installed. When there are sockets or studs, these shall be through-bolted, bonded or welded. The pulpit(s) and/or stanchions fitted to these shall be mechanically retained without the help of the lifelines. Without sockets or studs, pulpits and/or stanchions shall be through-bolted, bonded or welded. 1 2 3 4 5
- (g) The bases of pulpits and stanchions shall not be further inboard from the edge of the appropriate working deck than 5% of maximum beam or 150 mm, whichever is greater. 1 2 3 4 5
- (h) Stanchion bases shall not be situated outboard of a working deck. For the purpose of this rule a stanchion or pulpit base shall be taken to include a sleeve or socket into which a stanchion or pulpit tube is fitted but shall exclude a baseplate which carries fixings into the deck or hull. 1 2 3 4 5
- (i) Provided the complete lifeline enclosure is supported by stanchions and pulpit bases effectively within the working deck, lifeline terminals and support struts may be fixed to a hull aft of the working deck. 1 2 3 4 5
- (j) Lifelines need not be fixed to a bow pulpit if they terminate at, or pass through, adequately braced stanchions set inside and overlapping the bow pulpit, provided that the gap between the upper lifeline and the bow pulpit does not exceed 150 mm. 1 2 3 4 5
- (k) Stanchions shall be straight and vertical except that: 1 2 3 4 5

- (i) Within the first 50 mm from the deck, stanchions shall not be displaced horizontally from the point at which they emerge from the deck or stanchion base by more than 10 mm, and
- (ii) Stanchions may be angled to not more than 10 degrees from vertical at any point above 50 mm from the deck.

**3.12.4 Special requirements for pulpits, stanchions and lifelines on multihulls** 1 2 3 4

- (a) On a trimaran a bow pulpit on the main hull, with lifelines around the main hull supported on stanchions. The lifelines may be interrupted where there are nets or crossbeam wings outboard of the main hull.
- (b) On a trimaran where a net joins the base of a bow pulpit on the main hull, an additional lifeline from the top of the pulpit to the forward crossbeam at or outboard of the crossbeam mid-point.
- (c) On a trimaran at a main or emergency steering position on an outrigger with or without a cockpit, lifelines protecting an arc of 3.0 m diameter centred on the steering position (When measuring between lifelines their taut, undeflected positions shall be taken for this purpose).
- (d) On a catamaran lifelines from bow to stern on each hull. A catamaran without a forward or aft crossbeam shall have transverse lifelines at the extremity of the net forward and aft. The transverse lifelines shall be attached to bow and stern pulpits or superstructure. A webbing, strop or rope (minimum diameter 6 mm) shall be rove zig-zag between the transverse lifelines and the net.

<b>3.12.5</b>	<b>Lifeline height, vertical openings, number of lifelines</b>	
<b>LH</b>	<b>Minimum Requirements</b>	
Under 8.5 m	Taut double lifelines with the upper lifeline not less than 450 mm above the working deck.	1 2 3 4
8.5 m and over	Taut double lifelines with the upper lifeline not less than 600 mm above the working deck.	1 2 3 4

All	Intermediate lifeline(s) shall be fitted so that no vertical opening exceeds 380 mm.	1 2 3 4
All	The intermediate lifeline shall be not less than 230 mm above the working deck.	1 2 3 4

**3.12.6 Lifeline minimum diameters, required materials, specifications**

- (a) Where lifelines are fitted they shall be stranded stainless steel wire of minimum diameter specified in the table below. Lifelines shall be uncoated and used without close-fitting sleeving. 1 2 3 4 5 6 7
- (b) Notwithstanding [3.12.6 \(a\)](#) above, the term "uncoated" means that the wire must not be coated with any product that is moulded to the wire. The application of a loose sleeve to uncoated wire is permitted provided that air can circulate along the length of the wire between stanchions, it is regularly removed for inspection and the wire remains in good condition. 1 2 3 4 5 6 7
- (c) *Grade 316 stainless wire is recommended.* 1 2 3 4 5 6 7
- (d) A taut lanyard of synthetic rope may be used to secure lifelines provided the gap it closes does not exceed 100 mm. This lanyard shall be replaced at least annually. 1 2 3 4 5 6 7
- (e) All wire, fittings, anchorage points, fixtures and lanyards shall comprise a lifeline enclosure system which has at all points at least the breaking strength of the required lifeline wire. 1 2 3 4 5 6 7

LH	Minimum Wire Diameter	
Under 8.5 m	3 mm (1/8 in)	1 2 3 4 5 6 7
8.5 m – 13 m	4 mm (5/32 in)	1 2 3 4 5 6 7
over 13 m	5 mm (3/16 in)	1 2 3 4 5 6 7

**3.13 MULTIHULL NETS OR TRAMPOLINES**

- 3.13.1 The word "net" is interchangeable with the word "trampoline". 1 2 3 4  
 A net shall be: 1 2 3 4
  - (a) Essentially horizontal.
  - (b) Made from durable woven webbing, water permeable fabric, or mesh with openings not larger than 50.8 mm in any dimension. Attachment points shall be planned to

avoid chafe. The junction between a net and a yacht shall present no risk of foot trapping.

- (c) Solidly fixed at regular intervals on transverse and longitudinal support lines and shall be fine-stitched to a bolt rope.
- (d) Able to carry the full weight of the crew either in normal working conditions at sea or in case of capsize when the yacht is inverted.
- (e) Individually tied at each tie point of the net and not continuously connected to more than four attachment points per connecting line.

### 3.13.2 Trimarans with double crossbeams

A trimaran with double crossbeams shall have nets on each side covering:

1 2 3 4

- (a) The rectangles formed by the crossbeams, central hull and outriggers.
- (b) The triangles formed by the aft end of the central pulpit, the mid-point of each forward crossbeam, and the intersection of the crossbeam and the central hull.
- (c) The triangles formed by the aftermost part of the cockpit or steering position (whichever is furthest aft), the mid-point of each after crossbeam, and the intersection of the crossbeam and the central hull. Except that:
- (d) The requirement in [3.13.2\(c\)](#) shall not apply when cockpit coamings and/or lifelines are present which comply with the minimum height requirements in [3.12.5](#).

### 3.13.3 Trimarans with single crossbeams

A trimaran with single crossbeams shall have nets between the central hull and each outrigger on each side between two straight lines from the intersection of the crossbeam and the outrigger, respectively to the aft end of the pulpit on the central hull, and to the aftermost point of the cockpit or steering position on the central hull (whichever is furthest aft).

1 2 3 4

### 3.13.4 Catamarans

On a catamaran the total net surface shall be limited:

1 2 3 4

- (a) Laterally by the hulls.
- (b) Longitudinally by transverse stations through the forestay base, and the aftermost point of the boom lying fore and aft. However, a catamaran with a central nacelle (non-immersed) may satisfy the regulations for a trimaran.

**3.14 TOE RAIL OR FOOT-STOP**

**3.14.1** A toe rail of minimum height 25 mm shall be permanently installed around the foredeck from abreast the mast, except in way of fittings and not further inboard from the edge of the working deck than one-third of the local half-beam.

For boats with an Age Date before 01/1981 a toe rail of 20 mm is acceptable.

**3.14.2** A toe rail is not required on multihulls.

**3.15 TOILET**

**3.15.1** Toilet, securely installed shall be provided.

**3.15.2** Toilet or securely fastened bucket shall be provided.

**3.16 BUNKS**

**3.16.1** Bunks, securely fastened, sufficient for at least half the crew shall be provided.

**3.16.2** Bunks shall be suitable for use at sea. Fixed bunks shall be fitted with lee cloths or restraints where necessary (not normally required for pipe-cots).

**3.17 GALLEY**

**3.17.1** Cooking stove or heating appliance, capable of being safely operated in a seaway (e.g. Gimballed).

**3.17.2** Cooking stove or heating appliance, where installed shall be securely fastened, with safe, accessible fuel shutoff control.

**3.17.3** Gas may only be used for cooking.

(a) The use of petrol (or similar hydrocarbon with a flash-point below 60 °C) for lighting, cooking or heating is prohibited.

1	2	3	4				
1	2	3	4	5	6	7	
1	2						
		3	4	N			
1	2	3					
1	2						
1	2	3					
1	2	3	4	5	6	7	
1	2	3	4	5	6	7	



<b>(b)</b>	Methylated spirits is acceptable for cooking.	1 2 3 4 5 6 7
<b>3.17.4</b>	A sign reading "REMEMBER Turn Off Gas At Bottle" shall be displayed near any gas appliance.	1 2 3 4 5 6 7
<b>(a)</b>		
<b>(b)</b>	Boats equipped with gas systems using permanent flames, e.g. a pilot light, shall be fitted with a combustible gas detection system.	
<b>3.17.5</b>	Disposable gas cooking canisters used inside the boat must be no more than 225 gram capacity.	1 2 3 4 5 6 7
<b>3.17.6</b>	Gas bottles, cylinders and reserve canisters shall be contained in separate ventilated and self-draining compartments where vapour can only escape overboard.	1 2 3 4 5 6 7
<b>3.17.7</b>	Galley facilities - suitable facilities shall be provided.	1 2 3
<b>3.18</b>	<b>WATER TANKS AND WATER</b>	
<b>3.18.1</b>	Water tanks, permanently installed and capable of dividing the water supply into at least two compartments and discharging through a pump shall be provided. A leak in any one position in the fresh water system shall not result in the loss of more than two-thirds of the total water supply.	1 2
<b>3.18.2</b>	At least 2.5 litres of fresh water or a watermaker capable of producing 2.5 litres per crew member per 100 nautical miles of the course to be sailed shall be carried at the start of the race.	1 2
<b>3.18.3</b>	At least 2.5 litres of fresh water or a watermaker capable of producing 2.5 litres per crew member shall be carried at the start of the race. At least one securely installed water tank shall be provided for boats with an Age Date of 07/1998 or later.	3
<b>3.18.4</b>	Emergency drinking water: at least 1 litre of water per crew member in addition to that required by clauses <a href="#">3.18.2</a> and <a href="#">3.18.3</a> shall be carried in a dedicated container or containers.	1 2 3 4 5
<b>3.19</b>	<b>HANDHOLDS</b>	
<b>3.19.1</b>	Adequate handholds shall be fitted below decks so that crew members may move about safely at sea.	1 2 3 4 5

**3.20 BILGE PUMPS AND BUCKETS**

- |                     |   |               |
|---------------------|---|---------------|
| <b>3.20.1</b>       | Two manual bilge pumps, securely fitted to the boat's structure, one operable above and the other below deck shall be provided. Each pump shall be operable with all cockpit seats, hatches and companionways shut and shall be provided with permanently fitted discharge pipe(s) of sufficient capacity to accommodate simultaneously both pumps. | 1 2           |
| <b>3.20.2</b>       | Multihulls shall have provision to pump out all watertight compartments except those filled with impermeable buoyancy.  | 1 2 3 4       |
| <b>3.20.3</b>       | One manual bilge pump shall be provided and operable with all cockpit seats, hatches and companionways shut.  | 3             |
| <b>3.20.4</b>       | One manual bilge pump shall be provided.  | 4             |
| <b>3.20.5</b>       | One manual bilge pump shall be provided if the space below the floorboards precludes access of a bucket for bailing.  | 5             |
| <b>3.20.6</b>       | No bilge pump may discharge into a cockpit unless the cockpit opens aft to the sea. Bilge pumps shall not be connected to cockpit drains.   | 1 2 3 4 5 6 7 |
| <b>3.20.7</b>       |   |               |
| <b>(a)</b>          | Bilge pumps shall have a 25 mm minimum bore suction.  | 1 2 3 4 5 6 7 |
| <b>(b)</b>          | Bilge pumps and strum boxes shall be readily accessible for maintenance and for cleaning out debris.  |               |
| <b>3.20.8</b>       | Unless permanently fitted, each bilge pump handle shall be provided with a lanyard or catch or similar device to prevent accidental loss.   | 1 2 3 4       |
| <b>3.20.9</b>       | Two buckets of stout construction each with at least 8 litres capacity shall be provided. Each bucket is to have a lanyard.   | 1 2 3 4 5 6 7 |
| <br>                |   |               |
| <b>3.21 COMPASS</b> |   |               |
| <b>3.21.1</b>       | A marine magnetic compass, independent of any power supply permanently installed and correctly adjusted with deviation card shall be provided.  | 1 2 3 4       |
| <b>3.21.2</b>       | Spare magnetic compass independent of any power supply, capable of being used as a steering compass shall be provided.  | 1 2 3         |

**3.22 HALYARDS**

No mast shall have less than two halyards, each capable of hoisting a sail. 1 2 3 4 5

**3.23 NAVIGATION LIGHTS**

**3.23.1** Navigation lights shall be carried that conform to the International Regulations for Preventing Collisions at Sea (Part C and Technical Annex 1) and shall be exhibited as required by those regulations. 1 2 3 4 N

LH power	Guide to minimum filament bulb
Under 12 m	10 W
Tricolour	25 W
12 m and above	25 W

**3.23.2** Navigation lights shall be mounted so that they will not be masked by sails or the heeling of the boat. 1 2 3 4 N

**3.23.3** Navigation lights shall not be mounted below deck level and should be at no less height than immediately under the upper lifeline. 1 2 3 4 N

**3.23.4** Reserve navigation lights capable of being quickly mounted, with a power supply independent of the boat’s main supply shall be provided. 1 2 3 4 N

**3.23.5** Spare bulbs for navigation lights shall be carried except for lamps with multiple LED arrays. 1 2 3

**3.24 ENGINES, GENERATORS, FUEL**

**3.24.1 MONOHULLS** 1 2

A permanently installed inboard propulsion engine shall be provided together with permanently installed exhaust and fuel supply systems and fuel tank(s). The engine shall be securely covered and adequately protected.

**3.24.2 MULTIHULLS**

1 2

A permanently installed propulsion engine shall be provided.

**The remaining clauses of regulation 3.24 apply to both Monohulls and Multihulls.**

**3.24.3** A propulsion engine shall be provided, either in accordance with [3.24.1](#) and [3.24.2](#) above, or an outboard engine with associated tanks and fuel supply systems, all securely fastened. 3 4 5

**3.24.4** Motors used outboard shall be mounted at all times and the mounting may be raised but not removed. 3 4 5

**3.24.5** A propulsion engine required by these regulations shall: 1 2 3 4 5

**(a)** Provide a minimum speed in knots of  $(1.8 \times \sqrt{LWL}$  in metres) against a 12 knot headwind.

**(b)** Have a minimum amount of fuel which shall be sufficient to be able to meet charging requirements for the duration of the race and to motor at the above minimum speed for at least 8 hours (4 hours Cat 5).

**(c)** *Notwithstanding the above it is recommended that the minimum amount of engine fuel to be carried at the start of the race should be at least*

$$\text{Litres} = LWL (\text{metres}) / 0.135$$

1

$$\text{Litres} = LWL (\text{metres}) / 0.2$$

2

$$\text{Litres} = LWL (\text{metres}) / 0.4$$

3 4 5 6

**(d)** *Race committees are recommended to apply their own minimum fuel requirements in the notice of race which shall not be less than [3.24.5\(c\)](#) above.* 1 2 3

**3.24.6** When an electric starter is the only provision for starting the engine, a separate battery shall be carried, the primary purpose of which is to start the engine. 1 2 3 4 5 6 7

**3.24.7** A separate generator for electricity is optional. However, when a separate generator is permanently installed it shall be securely covered, and shall have permanently installed exhaust and fuel supply systems and fuel tank(s). 1 2 3 4 5 6 7

**3.24.8** Fixed fuel tanks shall have a shut off valve or cock fitted directly to the tank outlet except when it is not possible 1 2 3 4 5 6 7

- for fuel to escape or siphon from the tank if the fuel line fractures.
- 3.24.9**
- (a) Petrol fuel tanks for inboard engines or inboard tanks for outboard engines shall be permanently installed, metal, vented to the open air, electrically grounded and have the filler positioned so that spillage and fumes cannot enter the boat. 1 2 3 4 5 6 7
  - (b) Diesel fuel tanks shall be metal or other material certified as suitable by the manufacturer. 1 2 3 4 5 6 7
  - (c) Fuel lines shall be metal, and clipped rigidly in place with a flexible connection between the fixed line and the engine, or a flexible line may be used throughout provided that the material and terminals are designed for that purpose. In the case of petrol engines the flexible fuel line shall be fire resistant and appropriately coded by the manufacturer (e.g. with a red stripe). 1 2 3 4 5 6 7
  - (d) Outboard motor remote fuel tanks and lines shall be as supplied by the manufacturer or built to a recognised national standard and branded with their mark of approval. Fuel tanks shall be secured to the deck or in a separately ventilated compartment. 3 4 5 6 7
  - (e) Petrol fuel shall not be carried below decks in portable containers. 3 4 5 6 7
  - (f) Except for permanently installed linings or liners, a flexible tank is not permitted as a fuel tank. 3 4 5 6 7
- 3.24.10** Paddles: If not fitted with an engine, each boat 5.5 m or less shall carry a pair of oars or paddles with a minimum blade area of 0.04 m<sup>2</sup> each. 6 7

**3.25 MARINE RADIO**

- 3.25.1** The following waterproof or marine standard communication equipment shall be provided: 1 2 3 4 5
- (a) Means to communicate a distress situation to the Rescue Coordination Centre and Organising Authority. 1 2
    - (i) Permanently installed HF transceiver. All new HF transceivers shall be DSC capable.  
*It is recommended that all HF transceivers be DSC capable.*

<p>(ii) Satellite phone, incorporating voice and SMS capability, retained in a securely fastened mounting, connected to the vessel's electrical supply, equipped with a permanently located external aerial, and continuous coverage for the race area.</p> <p>(iii) Where shore based VHF facilities exist for the entire length of the course, the organising authority may permit an installed VHF transceiver only and this shall be included in the notice of race.</p> <p><b>(b)</b> (i) Permanently installed VHF transceiver All new permanently installed VHF transceivers shall be DSC capable.</p> <p>(ii) A waterproof handheld transceiver.</p> <p>(iii) A new permanently installed, or waterproof handheld, VHF transceiver.</p> <p>(iv) <i>It is recommended that all permanently installed VHF transceivers be DSC capable, each with their own unique MMSI.</i></p> <p>(v) Each handheld VHF DSC transceiver should have its own MMSI number allocated to the device, separate to that of the vessel.</p> <p><b>3.25.2</b> Where permanently installed, DSC HF/VHF transceivers shall be programmed with an assigned MMSI (unique to the boat), and where there is a permanently installed GPS, be connected to a GPS receiver, and be capable of making distress alert calls as well as sending and receiving a DSC position report with another DSC equipped station. Periodically, a test call should be made which should be automatically acknowledged.</p> <p><b>Specifications and Testing</b></p> <p><b>3.25.3</b> Permanently installed HF transceivers shall be:</p> <p><b>(a)</b> Able to transmit and receive on the standard distress frequencies of 4125, 6215, 8291 kHz.</p> <p><b>(b)</b> Tested in accordance with the notice of race.</p> <p><b>3.25.4</b> Permanently installed VHF transceivers shall:</p>	<p></p> <p>2</p> <p>1 2 3 4</p> <p>1 2 3</p> <p>5 6</p> <p></p> <p>1 2</p> <p></p> <p>1 2</p> <p></p> <p>1 2 3 4 5</p>
--	--

- (a) Have a maximum rated output power of not less than 25W.
- (b) Have a mast head antenna. 1 2 3
- (c) Have transmission and reception with a base station at least 8 nautical miles distant. 1 2 3
- (d) Be tested in accordance with the notice of race. 1 2 3 4 5
- 3.25.5** The following emergency antenna shall be provided:
- (a) An alternative antenna, independent of the mast for each required transceiver and satellite phone. At all times a boat shall maintain VHF and AIS capability. 1 2 3
- (b) An emergency antenna where the regular antenna depends upon the mast. 4
- 3.25.6** Handheld VHF transceivers shall: 1 2 3 4 5
- (a) Have a maximum rated output power of not less than 5W.
- (b) Be tested in accordance with the notice of race.
- 3.25.7** At least two means of receiving weather bulletins shall be provided. 1 2 3 4

### Training

- 3.25.8** Licensed Operators:  
All marine radio users must be appropriately qualified. A certificate of proficiency or statement of attainment, as recognised by the Australian Communications and Media Authority (ACMA), or an internationally recognised equivalent, is required to be held by the operator for the equipment being operated in the given race category.
- (a) At least two operators for the radio equipment listed in the race category. 1 2
- (b) At least one operator for the radio equipment listed in the race category. 3 4 5 6
- (c) Where there are only two crew on board, both crew members must meet the licence requirements. 1 2 3 4
- 3.26 BATTERIES (See also [3.24.6](#))**
- Batteries shall be of a sealed type from which liquid electrolyte cannot escape. 1 2 3

**3.27 BAROMETER**

A barometer shall be fitted.

1 2

**3.28 HULL IDENTIFICATION**

**3.28.1** Boats shall have on both sides or on the transom in legible characters a minimum of 50 mm high:

1 2 3 4 5 6 7

(a) The boat's name.

(b) Its state marine authority number or sail number.

(c) If the boat has no state marine authority number, the sail number and the name of the club.

(d) The name of the club may be abbreviated.

**3.28.2** Boats shall have either on the deck or on each side near the bow, an identification number which is either the boat's sail number or a race number specifically provided by the race organiser as specified in the notice of race.

1

The number shall be in a highly visible contrasting colour to the background hull or colour patch.

**3.28.3** Each multihull shall show on the underside, where they can be seen when inverted, not less than 2 areas of highly visible colour (e.g. Day-glow pink, orange or yellow) of at least 1 m<sup>2</sup> each.

1 2 3 4

**3.29 AUTOMATIC IDENTIFICATION SYSTEM (AIS)**

**3.29.1** The following shall be provided:

(a) An AIS Transponder.

1 2

(b) *An AIS Transponder is recommended.*

3

(c) From 1 July 2022 an AIS Transponder.

3

(d) Yachts shall ensure that both the yacht name and MMSI number are transmitted and shall ensure their AIS Transponder is switched on (i.e. transmitting and receiving) at all times.

(e) AIS transponders shall be tested and operated in accordance with the notice of race.

1 2 3

**3.30 GPS**

**3.30.1** A permanently installed GPS

1 2 3



## SECTION 4 - PORTABLE EQUIPMENT AND SUPPLIES

For water and fuel see [3.18](#) and [3.24](#)

### 4.01 SAIL NUMBERS

**4.01.1** Sail numbers shall be carried in accordance with RRS 77 and Appendix G.

**4.01.2** A separate piece of heavy-duty material shall be carried with the boat's sail numbers on it, with eyelets and lashings, capable of being displayed across the deck or along the lifelines when none of the numbered sails are set.

### 4.02 PLUGS (See [3.09.1](#))

### 4.03 JACKSTAYS, CLIPPING POINTS AND STATIC SAFETY LINES

#### 4.03.1 Jackstays

**(a)** Jackstays shall be attached to through-bolted or welded deck plates or other suitable and strong anchorage points fitted on deck, one port and one starboard of the boat's centreline to provide secure attachments for safety harness. Jackstays shall extend far enough to allow crew to hook on without leaving the cockpit.

**(b)** Jackstays shall be comprised of uncoated stainless steel 1 x 19 wire of minimum diameter 5 mm (3/16in), or spectra rope, or webbing, of equivalent strength (*20000 N (2040kgf) breaking force webbing is recommended*).

**(c)** At least two jackstays shall be fitted on the underside of a multihull in case of inversion.

**(d)** All fastenings and lashings for jackstays shall have the equivalent strength as the jackstay.

**(e)** Stanchion bases shall not be used as strong points.

#### 4 03.2 Clipping Points

**(a)** Clipping points shall be attached to through-bolted or welded deck plates or other suitable and strong anchorage points adjacent to stations such as the helm, sheet winches and masts, where crew members work for long periods.

### RACE

### CATEGORY

1 2 3 4 5 6 7

1 2 3

1 2 3 4 5

1 2 3

1 2 3 4

*(Warning: U-bolts can cause plain snap hooks to "capsize" when rotated on one leg of the u-bolt so that the "gate" bears against the other leg. For this reason the use of plain snap hooks is not recommended.)*

- (b)** Clipping points shall enable a crew member:
  - (i) To clip on before coming on deck and unclip after going below.
  - (ii) Whilst continuously clipped on, to move readily between the working areas on deck and the cockpit(s) with the minimum of clipping and unclipping operations.
- (c)** There shall be sufficient clipping points to enable two-thirds of the crew to be simultaneously clipped on without depending on jackstays.
- (d)** In a trimaran with a rudder on the outrigger, there shall be adequate clipping points that are not part of the deck gear or the steering mechanism, in order that the steering mechanism can be reached by a crew member whilst clipped on.

**4.04 FIRE EXTINGUISHERS**

Where there is any form of auxiliary engine or naked flame, fire extinguishers readily accessible in suitable and different parts of the yacht shall be provided as follows:

- 4.04.1** At least two, of a minimum 10B(E) rating each of dry powder or equivalent 1 2 3 4
- 4.04.2** One of a minimum 10B(E) rating of dry powder or equivalent 5 6 7
- 4.04.3** From 1 July 2021 all fire extinguishers will be of a minimum rating of 1A:10B(E). 1 2 3 4 5 6 7
- 4.04.4** A fire blanket adjacent to every cooking device with an open flame which should be used in the first instance on cooking fat fires. 1 2 3 4 5 6 7

**Notes:**

- 1. More than two, or higher rating extinguishers may be required depending upon the size and layout of the boat.*
- 2. Fire extinguishers are recommended to be inspected at least every six months. All extinguishers other than carbon dioxide have a pressure gauge indicating their*

state of charge, and a security seal on the trigger. They should be free of corrosion, and recharged if the seal is broken or the gauge is not in the green sector of the scale. The nozzle should be checked to ensure that it is clear. A dry chemical extinguisher should be taken from its bracket and shaken to prevent the powder inside from compacting. A carbon dioxide extinguisher needs to be checked by weight and recharged if there has been a loss of more than 10 per cent of the net weight.

3. A more thorough check by a competent person is recommended to be carried out annually and every few years when an extinguisher requires a discharge, refill, pressure test or replacement.

**4.05 ANCHORS**

**4.05.1**

- (a) Anchors and ground tackle shall be carried according to [Table 1](#). 1 2 3 4 5 6 7
- (b) Anchors and warps shall be sized according to [Table 2](#) or [Table 3](#) using the lesser as a minimum. Anchors of equivalent holding power shall be acceptable 1 2 3 4 5 6 7
- (c) The primary anchor shall be carried assembled and attached to the ground tackle. 1 2 3 4
- (d) A provision for securing the bitter end of the warp to a strong point on the boat prior to deploying the anchor shall be fitted. 1 2 3 4 5 6 7

*Note: For multihulls, owners are recommended to consider selecting an anchor and accompanying rode that is one size bigger, compared to a monohull of similar length overall.*

**TABLE 1 Number of Anchors and Length of Warps**

Function	Minimum length of chain	Plus length of Rope or Chain	
Primary anchor	10.0 m	50.0 m	1 2 3 4
Secondary anchor	2.0 m	40.0 m	1 2 3 4
Primary anchor	5.0 m	45.0 m	5 6 7

**GROUND TACKLE SIZES**  
**TABLE 2 - BASED ON L.O.A.**

LOA	ANCHOR High Holding Power		CHAIN	WARP	Suggested Warp Size	
	Plough Type e.g. CQR	Spade Type e.g. Danforth			Standar d Link	Minimum Breaking Force
Metres	kg	size	mm	kN	mm	mm
Under 5	3.5	4S	6	4.5	8	8
Up to 6	4	8S	6	9	10	10
Up to 8	7	13S	6	9	10	10
Up to 9	9	22S	8	20	16	12
Up to 11	11	22S	8	30	20	14
Up to 13	15	40S	10	39	24	16
Up to 15	20	65S	10	39	24	16
Up to 17	25	65S	13	45	26	18
Up to 19	34	80S	13	45	26	18
Over 19 as certified by a marine engineer.						

**TABLE 3 - BASED ON DISPLACEMENT**

Displac- ement	ANCHOR High Holding Power		CHAIN	WARP	Suggested Warp Size	
	Plough Type e.g. CQR	Spade Type e.g. Danforth			Standar d Link	Minimum Breaking Force
Kg	kg	size	mm	kN	mm	mm
Less than 815	4	8S	6	9	10	10
816 - 2500	7	13S	6	9	10	10
2501 - 4300	9	22S	8	20	16	12
4301 - 6550	11	22S	8	30	20	14
6551 - 9500	15	40S	10	39	24	16

SECTION 4 - PORTABLE EQUIPMENT AND SUPPLIES

9501 - 13600	20	65S	10	39	24	16
13601 - 20400	25	65S	13	45	26	18
20401 – 27200	34	80S	13	45	26	18
27201 and over	45	80S	14	60	32	20

Minimum breaking force should in no way be construed as a safe working load.

**4.06 SPOTLIGHTS AND FLASHLIGHTS**

- 4.06.1 (i) A watertight, high-powered spotlight, suitable for searching for a person overboard at night and for collision avoidance with spare batteries and bulbs (if they can be replaced).
- (ii) Flashlights, water resistant and floating type, with spare batteries and bulbs (if they can be replaced). At least three shall be provided.  
At least two shall be provided.
- 4.06.2 Flashlight, at least one water resistant and floating type, with spare batteries and bulb if they can be replaced.

1 2 3

1

2 3

4 5

**4.07 MEDICAL KIT AND MANUAL**

- 4.07.1 Ship Captain’s Medical Guide (21st edition or later).  
OR International Medical Guide for Ships, World Health Organization shall be provided.
- 4.07.2 “First Aid” - Authorised manual of the St. John Ambulance Assn. In Australia (current edition)  
OR “The Authorised Manual of the Australian Red Cross Society” (current edition).  
OR equivalent First Aid manual shall be provided.
- 4.07.3 *Injury/Illness Chart*  
*It is recommended that an injury/illness chart be used to help in communication over the radio or to ambulance officers on shore about what first aid treatment has been*

1

2 3 4 5

1 2 3 4 5 6 7

- administered to an injury (See [Appendix G](#) for an example).*
- 4.07.4** Boats shall carry a first aid kit containing at least the items in [4.07.9](#)  
*It is recommended that boats should be equipped with a first aid kit whose contents and storage reflects the likely conditions and duration of the passage and the number of people aboard the boat.*
- 4.07.5** *Items contained in the first aid kits listed below are BASIC and it is recommended that they be increased on a pro rata basis when more than 10 crew are carried.*
- 4.07.6** At least two members of the crew  
 At least one member of the crew  
 Shall hold a current Senior First Aid (Apply First Aid/Provide First Aid) Certificate or equivalent, or be a practising medical practitioner. Each of these crew members shall also have undertaken the training required by SR 6.01.  
*It is strongly recommended that if injectable items are to be carried, that the members of the crew trained in first aid have additional training in the use of injectables.*  
*The person in charge of a boat is also recommended to review the specific circumstances of the boat, the race or cruise to be undertaken, the weather and sea conditions likely to be experienced and the time before medical assistance could be available to determine if this minimum level of first aid training is appropriate or whether further training is required.*
- 4.07.7** *It is recommended that if there is any possibility that special medication is needed, or medication allergies exist for any crew member, that crew member should obtain medical advice before racing and provide any necessary additional medication.*
- 4.07.8** The race committee shall recommend increased dosages be carried for those races where a boat is expected to be more than 4 days from a port of refuge where medical assistance can be obtained.
- 4.07.9** The first aid kit shall be stored in a waterproof container(s) which shall have the contents listed so as to

1	2	3	4	5	6	7
1	2	3	4	5	6	7
1						
	2					
1	2	3	4	5	6	7
1						
1	2	3	4	5	6	7

be visible without opening and shall contain the items listed below.

In the following list the generic product is indicated with common brand names in brackets. The quantities for each category are indicated under the category column (Refer [4.07.5](#)).

Alternate pharmaceuticals in equivalent amounts and having similar action to those stated are acceptable.

## **WARNING**

**IN AN EMERGENCY, MEDICAL ADVICE SHOULD FIRST BE OBTAINED FROM THE COAST RADIO OR BY CONTACTING A DOCTOR THROUGH THE CONDUCTING CLUB. THIS IS PARTICULARLY IMPORTANT:**

1. BEFORE ADMINISTERING PRESCRIPTION DRUGS, OR
2. BEFORE ADMINISTERING ASPIRIN OR NITROLINGUAL SPRAY FOR A SUSPECTED CARDIAC EMERGENCY (OTHER THAN WHEN USING THE VICTIM'S PERSONAL MEDICATION), OR
3. TREATING AN EYE INJURY, OR
4. TREATING SEVERE PAIN, OR
5. TREATING DIARRHOEA WHERE THE PATIENT ALSO HAS A FEVER, OR
6. TREATING SEVERE BURNS.

**THE ADMINISTRATION OF ALL PRESCRIPTION DRUGS GIVEN UNDER MEDICAL ADVICE MUST BE DOCUMENTED IN THE BOAT'S LOG AND WITNESSED, DETAILING THE DOCTOR'S NAME, TREATMENT ADMINISTERED, DATE AND TIME.**

***NOTE:***

Check Expiry Date of all medications.

- \* Ask a pharmacist for this medication.
- \*\* Requires a prescription.
- \*\*\* Mandatory only when required by notice of race for long ocean races.

It should be noted that most prescription medication must be stored at a temperature of 25 °C or less.

*As the temperature in an enclosed yacht during the summer months can exceed 50 °C it is recommended that all prescription medication be replaced at least annually.*

All drugs are to be stored in a safe cool environment and morphine should be removed from the boat when the boat is not racing or the drug is not required for that race category.

The Australian Resuscitation Council (ARC) recommends that all those trained in CPR should refresh their CPR skills at least annually. CPR is the most fundamental skill in first aid and repeated training is important to improve the effectiveness of basic life support at sea.



	RACE CATEGORY						
	1	2	3	4	5	6	7
<b><u>FOR VARYING DEGREES OF PAIN</u></b>							
<b><u>Mild Pain</u></b>							
Paracetamol 500 mg (e.g. Panadol) OR Ibuprofen 200 mg (e.g. Nurofen)	40	40	40	20	20		
<b><u>Moderate to Severe pain</u></b>							
** Codeine 30 mg + Paracetamol 500 mg (e.g. Panadeine Forte)	20	20					
<b><u>Very Severe Pain</u></b>							
** Oxycodone 5 mg (e.g. Endone) OR	20	20					
** Oxycodone suppositories (per rectum) 30 mg (e.g. Proladone)	10	10					
*** Morphine 10 mg/1 ml	10	10					
<b><u>Opioid Overdose</u></b>							
*** Naloxone Hydrochloride ampoules 400 mcg/ml	5	5					
<b><u>Cardiac Emergencies</u></b>							
Soluble Aspirin (e.g. Disprin)	20	20	20	20	20	20	20
Nitrolingual Spray (e.g. Anginine)	1	1					
<b><u>FOR WOUNDS AND LIMBS</u></b>							
Butterfly or Steristrips (Strips of 5)	10	10	5	5			
Disposable Gloves	20	20	20	20	10	10	10
Crepe bandages 75 mm x 1.5 m	2	2	2	2	2	2	2
Crepe bandages 100 mm x 1.5 m	2	2					
Triangular bandage	2	2	1	1			
High Absorbency non-adherent dressing (e.g. Exu-Dry)	10	10					
Low Absorbency non-adherent dressing/plain gauze (e.g. Melolin)	10	10	10	10	5	5	2
Band-aids or equivalent roll of bandaid	20	20	20	20	20	20	20
Sports/Strapping tape 50 mm x 2.5 m (e.g. Leukoplast)	1	1					
Antiseptic skin solution 15 ml (e.g. Betadine)	1	1	1	1			
Antiseptic cream with Lignocaine HCL (e.g. Medcream)	1	1	1	1			
<b><u>FOR EYES</u></b>							

Normal saline (for washing) 250 ml	1	1	1	1			
Normal saline (for washing) 30 ml					2	2	2
** Chloramphenicol eye ointment 1% 4 mg	1	1					
Sterile eye patches	5	5					

**ANTIBIOTIC****Severe infection**

*** Ciprofloxacin 500 mg (e.g. Ciproxin, C-Flox, CiloQuin, Piprol, Profloxin)	14						
---	----	--	--	--	--	--	--

**For infection**

** Cephalixin 500 mg tabs (e.g. Keflex)	20	20					
---	----	----	--	--	--	--	--

**Fungal skin infection**

Clotrimazole cream (e.g. Lamisil, Daktarin)	1	1					
---	---	---	--	--	--	--	--

**FOR BURNS**

**Superficial** - Hydrogel wound dressing 100 g (e.g. Solosite, Duoderm Gel, Purilon)

**Severe** - Cool, then cover with a non-adherent dressing and obtain hospital treatment as soon as possible.

** Silver sulphadiazine cream 100 g (e.g. Flamazine)	1						
--	---	--	--	--	--	--	--

**SUNSCREEN**

30+ SPF 250 ml	1	1	1	1	1	1	1
----------------	---	---	---	---	---	---	---

**FOR DIARRHOEA/GASTRIC PROBLEMS**

Anti-diarrhoea treatment (pkt) - (e.g. Imodium, Lomotil)

Antacid tablets (pkt) or liquid (bottle)	1						
--	---	--	--	--	--	--	--

(e.g. Mylanta, Gaviscon)

**FOR DEHYDRATION**

Electrolyte replacement 4.9g sachet - pkt of 10 (e.g. Gastrolyte)	1	1					
---	---	---	--	--	--	--	--

**FOR SEASICKNESS**

Crews should consider carrying some form of seasickness remedy for all racing categories.

It should be noted that all types of seasickness remedy available may produce drowsiness and/or disorientation.

Travel/seasickness tablets (e.g. Avomine or Travacalm)

10 10 10 10

**FOR ALLERGY**

Known allergy sufferers should carry their own auto-injector (e.g. EpiPen, Anapen) or similar and advise the crew of its location and method of administration

\*\* Antihistamine 25 mg tablet (e.g. Phenergan)

25 25

\*\* Adrenaline ampoules 1:1000

5 5

**INSTRUMENTS**

Scissors, stainless steel

1 1 1 1 1 1 1

Thermometer, clinical

1 1

Forceps, splinter, stainless steel

1 1

Appropriately sized disposable syringes and needles (*to be increased to 20 if Morphine and Naloxone Hydrochloride ampoules are required by the Notice of Race*).

5 5

1 1

Alcohol swabs for injection preparation

0 0

\*\*\* Stapling kit/wound glue

1

**EMERGENCY MEDICAL EQUIPMENT**

Malleable or fixed splints appropriate for arms and legs (e.g. inflatable, SAM, Flex-All)

1 1

CPR mask or 6 Face shields

1 1 1 1 1 1 1

**4.08 FOGHORN**

1 2

**4.09 INTENTIONALLY BLANK**

**4.10 CHARTS, PILOTING EQUIPMENT AND BOOKS**

**4.10.1**

(a) Navigational charts for the current race (not solely electronic), and chart plotting equipment shall be provided. 1 2 3 4 5

(b) Charts shall contain details of likely ports of refuge.

(c) A list of lights or navigational charts which show details of lights likely to be visible from the race area shall be provided.

**4.10.2** The current “International Regulations for the Prevention of Collision at Sea” shall be provided in either electronic or hardcopy formats. 1 2 3 4

**4.10.3** The current “Australian Sailing Racing Rules of Sailing” and “Special Regulations Part 1” shall be provided in either electronic or hardcopy formats, except in open boats. 1 2 3 4 5 6 7

**4.11 GPS**

**4.11.1** A GPS which may be handheld and water resistant with a spare battery(s). 4

**4.11.2** A second GPS which is handheld and water resistant with a spare battery(s) shall be provided. 1 2

**4.11.3** A yacht shall be equipped with an EPFS (e.g. GPS) capable of recording a man overboard position within 10 seconds and monitoring that position. 1 2

**4.12 DEPTH SOUNDER** 1 2 3

**4.13 LOG**

**4.13.1** A distance measuring instrument (other than GPS) shall be provided. 1 2 3

**4.14 EMERGENCY STEERING**

**4.14.1** An emergency tiller capable of being fitted quickly to the rudder stock where the normal method of steering 1 2 3 4 N

	is other than by a strong tiller fitted directly to the rudder stock shall be provided.								
<b>4.14.2</b>	Crews must be aware of alternative methods of steering the boat in any sea condition in the event of rudder loss. At least one method must have been proven to work on board the boat. An inspector may require that this method be demonstrated.	1	2	3	4	N			
<b>4.15</b>	<b>TOOLS AND SPARE PARTS</b>								
<b>4.15.1</b>	Tools and spare parts, including effective means to disconnect or sever the standing rigging from the hull in case of need shall be provided.	1	2	3	4	5			
<b>4.15.2</b>	A bosun’s chair or climbing harness shall be provided. <i>It is recommended that a bosun’s chair be carried in addition to a climbing harness.</i>	1	2	3	4				
<b>4.15.3</b>	A sharp knife capable of cutting high modulus fibre rope, sheathed and restrained located in or near each cockpit shall be provided.	1	2	3	4	5	6	7	
<b>4.16</b>	<b>BOAT’S NAME</b>								
<b>4.16.1</b>	A boat’s name shall be placed on miscellaneous buoyant equipment, such as lifejackets, cushions, lifebuoys, lifeslings, floor boards etc.	1	2	3	4	5	6	7	
<b>4.16.2</b>	Where a lifejacket is the personal equipment of a crew member it shall be marked instead to identify the owner. Preferably this should be the name of the owner and a contact telephone number.	1	2	3	4	5	6	7	
<b>4.17</b>	<b>RETROREFLECTIVE TAPE</b>								
	Marine grade retroreflective material shall be fitted to lifebuoys, lifeslings, liferafts and <b><i>is recommended on lifejackets not required by a Standard to have such material.</i></b>	1	2	3	4	5	6	7	
<b>4.18</b>	<b>EPIRBS</b>								

<b>4.18.1</b>	A GPS capable 406 MHz Emergency Position Indicating Radio Beacon (EPIRB) registered with a national registration authority:	1	2	3
<b>(a)</b>	Shall be provided.	1	2	3
<b>(b)</b>	Shall be provided for races that extend more than two nautical miles offshore.			4
<b>4.18.2</b>	The number of EPIRBs carried on board shall be not less than the number of liferafts carried on the boat.	1	2	
<b>4.18.3</b>	EPIRBs shall be:	1	2	3 4
<b>(a)</b>	Stored in a dry, well-marked location near the companionway.			
<b>(b)</b>	Within battery life.			
<b>(c)</b>	Regularly tested to ensure they are in working condition.			
<b>(d)</b>	Registered in the boat's name. Crew members shall be trained in the use of this equipment.			
<b>4.18.4</b>	Additional EPIRBs required under <a href="#">4.18.2</a> may be packed in each liferaft or stored in a dry, well-marked location near the companionway.	1	2	
<b>4.19</b>	<b>LIFERAFTS</b>			
<b>4.19.1</b>	<b>Liferaft Construction</b>	1	2	
<b>(a)</b>	One or more inflatable liferafts with a total capacity to accommodate at least the total number of people on board which complies with:			
<b>(i)</b>	SOLAS LSA Code 1997 Chapter IV or later version; or			
<b>(ii)</b>	ISO 9650-1:2005, Type 1, Group A - Small Craft - Inflatable; or			
<b>(iii)</b>	ISAF liferafts manufactured before 2016 until replacement is due at end of service life; or			
<b>(iv)</b>	ORC liferafts manufactured before 2003 until replacement is due at end of service life			
<b>(v)</b>	USL Coastal liferaft manufactured before 1 July 2006 until replacement is due at end of service life			
<b>4.19.2</b>	<b>Minimum Liferaft Equipment</b>	1	2	

- (a) A SOLAS liferaft shall contain as a minimum a SOLAS A pack;
- (b) An ISO 9650 liferaft shall contain as a minimum Pack 2 (less than 24 hour pack);
- (c) ISAF liferaft shall contain at least an ISAF pack;
- (d) ORC liferafts shall contain at least an ORC pack;
- (e) USL Coastal liferaft when each liferaft shall contain at least an Australian Sailing pack (SR Part 1, [Appendix A](#)).
- (f) When the notice of race requires yachts to carry Pack 1 (>24h) or Australian Sailing equipment (SR Part 1, [Appendix A](#)), the additional equipment above that required by [4.19.2 \(a-e\)](#), shall be either packed into the liferaft or carried in a grab bag.

#### 4.19.3 Liferaft Packing and Stowage

1 2

- (a) Each liferaft shall be packed either in:
  - (i) a rigid container securely stowed on the working deck, in the cockpit or in an open space; or
  - (ii) a rigid container or valise securely stowed in a dedicated weather tight locker containing liferaft and abandon ship equipment only which is readily accessible and opens onto the cockpit or working deck, or transom
- (b) In a boat with primary launch before June 2001, a liferaft may be packed in a valise not exceeding 40 kg securely stowed below deck adjacent to a companionway
- (c) On a multihull or on a monohull with moveable ballast the liferaft shall be readily deployable whether or not the boat is inverted
- (d) The end of each liferaft painter should be securely fastened to the boat
- (e) Each raft shall be capable of being got to the lifelines or launched within 15 seconds

**NOTE:** *There are risks associated with long-term storage of liferafts in adverse weather conditions when yachts are not in use. Owners should consult*

*manufacturer's recommendations for care and stowage of liferafts.*

#### **4.19.4 Liferaft Servicing and Inspection**

1 2

*IMPORTANT NOTICE Evidence has shown that packaged liferafts are vulnerable to serious damage when dropped (e.g. from a boat onto a marina pontoon) or when subjected to the weight of a crew member or heavy object (e.g. an anchor). Damage can be caused internally by the weight of the heavy steel CO<sub>2</sub> bottle abrading or splitting neighbouring layers of buoyancy tube material. A liferaft should be taken for servicing if there is any sign of damage or deterioration (including on the underside of the pack). Persons in charge should insist on great care in handling liferafts and apply the rules NO STEP and DO NOT DROP UNLESS LAUNCHING INTO THE SEA.*

- (a)** A liferaft shall be serviced at a manufacturer authorized service station at the following maximum intervals:
- (i) SOLAS liferafts annually
  - (ii) ISO 9650 canister packed liferafts every 3 years
  - (iii) ISO 9650 valise packed liferafts every 3 years except that hired liferafts shall be serviced annually
  - (iv) ISAF liferafts annually
  - (v) ORC liferafts annually
- (b)** Servicing certificates (original or a copy) on board

#### **4.20 GRAB BAGS TO ACCOMPANY LIFERAFTS**

1 2

##### **4.20.1**

- (a)** *A yacht is recommended to have for each liferaft, a grab bag. A grab bag should have inherent flotation, at least 0.1 m<sup>2</sup> area of fluorescent orange colour on the outside, should be marked with the name of the yacht, and should have a lanyard and clip.*
- (b)** *NOTE: It is not intended to duplicate in a grab bag items required by other Special Regulations to be on*



*board the yacht - these recommendations cover only the stowage of those items.*

#### **4.20.2 Grab Bag Recommended Contents**

1 2

*The grab bag should be easily accessible. The following contents should be considered for inclusion and should be appropriately packed and waterproofed.*

- (a) Two red parachute and Two red hand flares and cyalume type chemical light sticks*
- (b) A waterproof handheld GPS in at least one of the grab bags carried by a yacht*
- (c) A SART (Search and Rescue Transponder) in at least one of the grab bags carried by a yacht*
- (d) A GPS capable 406MHz EPIRB in at least one of the grab bags carried by a yacht*
- (e) Water in re-sealable containers or a hand-operated desalinator plus containers for water*
- (f) A watertight handheld marine VHF transceiver plus a spare set of batteries*
- (g) A watertight flashlight with spare batteries and bulb*
- (h) Thermal protective aids or survival bags*
- (i) Two safety tin openers (if appropriate)*
- (j) A first-aid kit including sunscreen and seasickness tablets.*
- (k) A daylight signalling mirror*
- (l) Some high-energy food*

**NOTE: Additional recommended items for long Category 1 races**

- (m) A handheld satellite telephone with waterproof cover and internal batteries*
- (n) A strobe light*
- (o) Medical supplies for pre-existing medical conditions of any crew member*
- (p) Spare unbreakable spectacles for any crew members needing them*
- (q) Four additional red parachute flares, three white parachute flares, two orange smoke flares*

#### **4.21 LIFEBUOYS**

- 4.21.1** The following shall be provided within reach of the helmsman and ready for instant use: 1 2 3 4
- (a)** A lifebuoy with a self-igniting light and a drogue or a lifesling with a self-igniting light and without a drogue. 1 2 3 4
- (b)** In addition to (a) above, one lifebuoy within reach of the helmsman and ready for instant use, equipped with: 1 2
- (i)** A whistle, a drogue, a self-igniting light and
- (ii)** A pole and flag. The pole shall be either permanently extended or be capable of being fully automatically extended (not extendable by hand) in less than 20 seconds. It shall be attached to the lifebuoy with 3 m (10 ft) of floating line and is to be of a length and so ballasted that the flag will fly at least 1.8 m (6 ft) off the water.
- 4.21.2** When at least two lifebuoys (and/or lifeslings) are carried, at least one of them shall depend entirely on permanent (e.g. foam) buoyancy. 1 2
- 4.21.3** Each inflatable lifebuoy and any automatic device (e.g. pole and flag extended by compressed gas) shall be tested and serviced at intervals in accordance with its manufacturer's instructions. 1 2 3 4
- 4.21.4** Each lifebuoy or lifesling shall be fitted with marine grade retroreflective material. 1 2 3 4
- 4.21.5** The colour of a lifebuoy or lifesling, other than lines, fittings and retroreflective material shall be a safety colour in the yellow - red range. 1 2 3 4
- 4.22 PYROTECHNICS (FLARES)**
- 4.22.1** Pyrotechnic signals conforming to AS 2092 or higher (e.g. SOLAS LSA Code Chapter III Visual Signals) stored in waterproof container(s) shall be provided. The age of all pyrotechnics shall not exceed the manufacturer's expiry date. 1 2 3 4 5

Red parachute flares	Red hand flares	White hand flares *	Orange smoke	
6	4	2	4	1
4	4	2	4	2 3
	2	2	2	4
	2		2	5
* Specifications (except colour and candela rating) should comply with LSA Code Chapter III 3.2				

**4.23 HEAVING LINE**

**4.23.1** A 15 m – 25 m in length heaving line shall be readily accessible to the cockpit. It shall consist of a floating line with a buoyant object at one end. *The “throwing sock” type is recommended.*

1 2 3 4 5

**4.24 STORM AND HEAVY WEATHER SAILS**

**Design**

*It is strongly recommended that owners consult their designer and sailmaker to decide the most effective size for storm and heavy weather sails. The purpose of these sails is to provide safe propulsion for the boat in severe weather – they are not intended as part of the racing wardrobe. The areas below are maxima. Smaller areas are likely to suit some boats according to their stability and other characteristics.*

1 2 3 4

**4.24.1** Boats shall be equipped with sails suitable for use in heavy weather:

**(a)** A storm jib of area not greater than 5% x (height of the foretriangle (I) <sup>2</sup>, and luff maximum length 65% height of the foretriangle.

1 2

**(b)** A storm trysail capable of being sheeted independently of the boom with area not greater than 17.5% x (mainsail luff length x mainsail foot length), or mainsail reefing to reduce the luff by at least 50%.

1 2

The storm trysail shall have neither headboard nor battens.

	A storm trysail is not required in a yacht with a rotating wing mast which can adequately substitute for a trysail.	
(c)	A heavy-weather jib (or heavy-weather sail in a yacht with no forestay) of area not greater than 13.5% x (height of the foretriangle (l) <sup>2</sup> ), and without reef points.	1 2 3 4
(d)	Either a storm trysail as above or mainsail reefing to reduce the luff by at least 40%. <i>Note: It is strongly recommended that owners consult their designer and sailmaker to decide the most effective number of reefing points, size and the percentage of luff reduction for severe weather.</i>	3
<b>4.24.2</b>	<b>Construction</b>	
(a)	Every trysail and storm jib shall either be of highly visible coloured material (e.g. dayglow pink, orange or yellow) or have a highly visible coloured patch added on each side. A trysail or a storm jib purchased after July 2005 shall be made entirely of highly visible coloured material. Patches shall be in the upper half of the sail and be at least 20% of the area of the sail.	1 2 3
(b)	Sheeting positions shall be provided on deck for each storm and heavy-weather sail.	1 2 3 4
(c)	Each storm or heavy-weather jib which needs a stay shall have a means to attach the luff to the stay, independent of any luff-groove device.	1 2 3
(d)	Sail number and letters shall be on both sides of the trysail, and as large as practicable.	1 2 3 4
(e)	In a yacht with an in-mast furling mainsail, the storm trysail must be capable of being set while the mainsail is furled.	1 2 3 4
(f)	<i>It is recommended that sheets should be permanently attached to the storm jib by sewing or splicing, not by J clips.</i>	1 2 3 4
<b>4.24.3</b>	<b>Materials</b>	
(a)	Aromatic polyamides, carbon and similar fibres shall not be used in a trysail or storm jib but HMPE and similar materials are permitted.	1 2 3 4

**4.25 DROGUE, SEA ANCHOR**

*A drogue (for deployment over the stern), or alternatively a sea anchor or parachute anchor (for deployment over the bow) are recommended (See [Appendix F](#)).*

1 2 3

**4.26 RETRIEVAL OF CREW FROM THE WATER**

All boats shall be able to demonstrate equipment or method by which crew may be assisted back on board.

1 2 3 4 5 6

**4.27 DISTRESS SHEET**

A standard orange sheet 1.8 m x 1.2 m with a black “V” or black square above a black circle, with lanyards attached shall be carried.

1 2 3 4

**4.28 STOWAGE CHART**

**4.28.1** A durable stowage chart shall be provided and shall be displayed in the main accommodation area where it can best be seen, clearly marked with the location of the principal items of safety equipment.

1 2 3 4

## SECTION 5 - PERSONAL EQUIPMENT

---

### 5.01 LIFEJACKETS

Lifejacket requirements vary between the States and Territories and *it is recommended that before purchase and use it should be established that the lifejacket is acceptable under local law.*

- 5.01.1** Each crew member shall have one lifejacket as follows: 1 2 3 4 5 6 7
- (a)** A lifejacket complying with AS4758-2008 (minimum Level 150) or AS1512-1996 Type 1 (not less than 150N), or an equivalent or more stringent overseas standard such as ISO 12402 – 3 (Level 150) or ISO 12402-2 (Level 275). 1 2 3 4
- (b)** Lifejackets as above shall be arranged to securely suspend an unconscious person face upwards at approximately 45 degrees to the water surface in accordance with ISO 12402-3. 1 2 3 4
- (c)** Bulky inherently buoyant lifejackets that are applied over the head (known as “Mae West” type) are not acceptable. 1 2 3 4
- (d)** Each lifejacket shall have:
- (i) Marine grade retroreflective tape 1 2 3 4
  - (ii) A whistle attached 1 2 3 4
  - (iii) A crotch strap or thigh straps fitted. 1 2 3
  - (iv) From 1 July 2023 have a sprayhood. It is recommended that sprayhoods comply with ISO12402-8 1 2
- (f)** A boat shall carry: 1 2
- (i) at least one spare lifejacket as required in [5.01.1](#)
  - (ii) if inflatable lifejackets are carried, at least one gas inflatable lifejacket spare cylinder and, if appropriate, a spare activation head.

<b>(g)</b>	A lifejacket shall be worn by each member of the crew when on deck between the hours of sunset and sunrise.	1 2 3
<b>(h)</b>	<i>It is strongly recommended that a lifejacket be worn by each member of the crew at times such as, but not limited to:</i> <i>(i) When alone on deck</i> <i>(ii) When the true wind speed is 25 knots or above</i> <i>(iii) When visibility is less than 1 nautical mile.</i>	1 2 3
<b>(i)</b>	A lifejacket complying with AS4758-2015 (minimum Level 50) or AS1512-1996 Type 1 or Type 2, or equivalent or more stringent overseas standard.	5 6 7
<b>(j)</b>	On a boat without lifelines complying with <a href="#">3.12</a> , a lifejacket complying with <a href="#">5.01.1(i)</a> , shall be worn by each member of the crew while on deck.	5 6
<b>(k)</b>	A lifejacket complying with AS4758-2015 (minimum Level 100) or AS1512-1996 Type 1 (not less than 100N), or an equivalent or more stringent overseas standard, shall be worn by each member of the crew.	N
<b>5.01.2</b>	Each lifejacket shall be branded with the respective standard authority's mark of approval	1 2 3 4 5 6 7
<b>5.01.3</b>	A combined lifejacket and safety harness may be used so long as it meets the respective standard for each.	1 2 3 4 5 6 7
<b>5.01.4</b>	If inflatable, lifejackets shall have a compressed gas inflation system.	1 2 3 4 5 6 7
<b>5.01.5</b>	Each inflatable lifejacket shall be checked and serviced at the intervals and using the procedures as prescribed by the manufacturer. <i>Note: Users of inflatable lifejackets are advised to read the maintenance instructions provided with their lifejacket and undertake more frequent checks for lifejackets that are regularly wet. The RNLI has developed a guide for servicing and maintenance of inflatable lifejacket.</i>	1 2 3 4 5 6 7
<b>5.01.6</b>	Each lifejacket which is not an inflatable shall be checked annually for serviceability.	1 2 3 4 5 6 7
<b>5.02</b>	<b>SAFETY HARNESSES AND SAFETY LINES (Tethers)</b>	

**5.02.1**

- (a) Each crew member shall have a safety harness and a safety line, not more than 2 m in length. 1 2 3 4
- (b) Each safety harness and safety line shall comply with:
- (i) Australian Standard AS2227, or
  - (ii) An equivalent overseas standard such as ISO 12401, and
  - (iii) Shall be branded with the respective standard authority's mark of approval.
- (c) The safety line shall have a snap hook at each end.
- (d) *Warning: It is possible for a plain snap hook to disengage from a u-bolt if the hook is rotated under load at right-angles to the axis of the u-bolt. For this reason the use of snap hooks with positive locking devices is strongly recommended.*

**5.02.2**

- In addition to the requirement of [5.02.1\(a\)](#), at least 30% of the crew shall each be provided with either: 1 2
- (i) A safety line not more than 1 m long or
  - (ii) A mid-point manufacturer fitted snap hook attachment on a 2 m safety line or
  - (ii) Twin lines, one not more than 1 m long and the other not more than 2 m long.

*NOTE: Twin lines are a single safety line arrangement with three snap hooks. The centre hook is designed to be clipped to the harness. The other two hooks provide safety lines of not more than 1 m and not more than 2 m in length.*

- 5.02.3** A crew member's lifejacket and harness shall be compatible. 1 2 3 4

- 5.02.4** *It is strongly recommended that:* 1 2 3 4

- (a) *A harness should be fitted with a crotch strap or thigh straps.*
- (b) *Snap-hooks should be of a type which will not self-release from a u-bolt (See [5.02.1 \(d\)](#)) and which can be easily released under load (crew members are reminded that a personal knife or tether cutter may free them from a safety line in emergency).*
- (c) *A crew member before a race should adjust a harness to fit then retain that harness for the duration of the race.*



**5.02.5**

1 2 3 4

- (a) *Warning: A safety line and safety harness are not designed to tow a person in the water and it is important that the shortest safety line length possible be used with a harness to minimise or eliminate the risk of a person’s torso becoming immersed in water outside the boat, especially when working on the foredeck. The 1 m safety line or the midpoint snap hook on a 2 m line should be used for this purpose. The diligent use of a properly adjusted safety harness and the shortest line practicable are regarded as by far the most effective way of preventing man overboard incidents.*
- (b) *Warning: Twin lines are to be used for 2-point attachment to the vessel and not to be used as a single line tether 3 m in length.*

**5.03 PERSONAL LIGHTS**

A personal location light (either strobe or complying with SOLAS LSA 2.2.3), to be carried by or attached to each member of the crew when on deck at night.

1 2 3 N

**5.04 PERSONAL CLOTHING**

*It is recommended that during rough weather, crew that are on deck wear clothing that will protect them from hypothermia.*

1 2

**5.05 PERSONAL LOCATOR BEACON AND AIS PERSONAL CREW OVERBOARD BEACON**

**5.05.1**

- (a) A GPS capable 406 MHz Personal Locator Beacon (PLB) registered with a national registration authority shall be carried by or attached to each member of the crew when on deck.
- (b) It is recommended an AIS personal crew overboard beacon capable of communicating their position to their yacht and other nearby vessels be carried by or attached to each member of the crew when on deck.
- (c) Where a yacht is crewed by only two crew, both a PLB and AIS personal crew overboard beacon shall be

1 2

1 2 N

1 2 N

- |               |   |       |
|---------------|---|-------|
|               | carried by or attached to each crew member when on deck.  |       |
| <b>(d)</b>    | <i>It is recommended that the MMSI and crew name for AIS personal crew overboard beacon is recorded and kept on board and provided to the organising authority.</i> | 1 2 3 |
| <b>5.05.2</b> | PLBs and AIS personal crew overboard beacons shall be:  | 1 2   |
| <b>(a)</b>    | Within battery life   |       |
| <b>(b)</b>    | Regularly tested to ensure they are in working condition  |       |
| <b>(c)</b>    | Registered in the user's name.  |       |
| <b>5.05.3</b> | Crew members are to be trained in the use of this equipment.  | 1 2   |

**6.01 TRAINING****6.01.1**

**(a)** At least 50% of the crew

1

**(b)** At least 30% of the crew

2

including the skipper or sailing master shall have undertaken training in both theoretical and practical sessions in accordance with the Australian Sailing Safety and Sea Survival Course (SSSC), or a course of no less a standard acceptable to the race committee that covers as a minimum, the following topics **(Australian Sailing strongly recommends that all crew members do likewise):**

- Care and maintenance of safety equipment
- Storm sails
- Damage control and repair
- Heavy weather - crew routines, boat handling, drogues
- Man overboard prevention and recovery
- Giving assistance to other craft
- Hypothermia
- SAR organisation and methods
- Weather forecasting
- Liferafts and lifejackets
- Fire precautions and use of fire extinguishers
- Distress communications equipment (VHF, GMDSS, satcoms etc.)
- Pyrotechnics and EPIRBs

The training shall have a five year validity period. Revalidation shall be achieved by completing an update course in accordance with the SSSC.

**6.01.2 Routine Training on Board**

1 2 3 4 5 6 7

*It is recommended that crews should practise safety routines at reasonable intervals including the drill for man overboard recovery.*

**SECTION 7 - APPENDICES**

**APPENDIX A to Part 1**

**EQUIPMENT FOR USL COASTAL LIFERAFTS**

1 2

- 1.0** USL Coastal liferafts permitted under [4.19.1 \(a\)](#) shall carry at least the following equipment, properly stowed and secured so as to be available undamaged after launching and inflating:
- (a)** One sea anchor or drogue (attachment line should not be less than 15 m) attached so that the entry point to the liferaft is to leeward. (*Compliance with ISO 17339 or equivalent is recommended*).
  - (b)** One safety knife.
  - (c)** One bellows or hand pump for hand inflation that is of one piece, ready for use and does not require assembling.
  - (d)** One water resistant flashlight (signalling) together with one spare set of batteries and one spare bulb, if they can be replaced, in a waterproof container.
  - (e)** One heliograph mirror.
  - (f)** One bailer easily identifiable as such (*RAN specification recommended*).
  - (g)** One sponge per person.
  - (h)** One repair outfit complete with six emergency buoyancy tube leak stopping plugs capable of repairing punctures in buoyancy compartments.

- (i) One buoyant rescue quoit attached to at least 30 m of buoyant line.
- (j) Four red hand-flares and two smoke signals or combination of both complying with [4.22](#).
- (k) Two red parachute flares complying with [4.22](#).
- (l) One signalling mirror.
- (m) Sufficient drinking water, giving 0.5 l per person.
- (n) One pack of emergency rations per person.
- (o) Two tubes of sunscreen.
- (p) Five plastic bags, not less than 450 mm x 300 mm per person.
- (q) An operational instruction card clearly legible on the liferaft and its contents, either waterproofed or stencilled on the inside of the canopy or on the inside of the buoyancy compartments.
- (r) A USL Coastal First Aid Kit.
- (s) *A water maker is recommended for long Category 1 Races.*
- (t) Two buoyant paddles with handles.
- (u) Six anti-seasickness tablets for each person.
- (v) One waterproof copy of the illustrated table of life-saving signals referred to in Regulation 38 of Chapter V of SOLAS 1997.
- (w) One waterproof copy on how to survive in the liferaft.  
The above equipment must be packed in bags capable of holding it comfortably so that it does not burst out when opened in difficult conditions. The closure must be by a plastic zip or Velcro along the side and not at one end. The bags must be securely fastened to the inside of the liferaft.

**APPENDIX B to Part 1**

**RESISTANCE TO CAPSIZE FOR MONOHULLS**

**B.1 RESISTANT TO CAPSIZE**

**B.1.1 For all boats**

To be considered **Resistant to Capsize** as required in Regulation [3.04.1](#) boats shall be assessed as follows:

- The Stability Index of the ORC International Rule (ORCi) or
- The Category (ISO 12217-2) as detailed in [B.4](#) or
- The Category (STIX and AVS) from an IRC certificate or
- The SSS Base Value from the IRC certificate where the certificate does not show an IRC Category (STIX and AVS) or
- The Screening Value (SV) as provided in [B.5](#)
- The Righting Moment Index (RMI) as calculated in [B.5](#) or
- The Horizontal Stability Factor as calculated in [B.6](#).

**B.1.2** An additional requirement for boats with movable or variable ballast shall also comply with the relevant requirement of [B.7](#).

**B.2 RACE CATEGORIES**

**NOTE:** For Category 0 races refer to World Sailing requirements.

To demonstrate compliance with Resistance to Capsize requirements for the various race categories one of the following shall be achieved:

**Category 1** Races: ORCi Stability Index of 115 or greater, or ISO 12217-2 Design Category A except that the STIX Number shall be increased to a minimum of 35.

For Category 1 races, the hydrostatics and stability demonstrating the yacht's compliance with ISO Category A shall be derived from measurement of the freeboards and righting moment of the actual yacht by a qualified source

**NOTE:** *When determining stability criteria for an event, the organising authority should consider the limitations of ISO12217-2:2002 wherein it is stated:*

*8.2.1 A boat given design category A is considered to be designed to operate in winds of Beaufort force 10 or less and the associated wave heights, and to survive in more severe conditions.*

*And*

*8.2.4 Table 8 which limits significant wave height and wind speed in design category definitions as follows:*

Design category	A	B	C
Wave height up to	approx. 7 m significant	4 m significant	2 m significant
Typical Beaufort wind force	up to 10	up to 8	up to 6
Calculation wind speed (m/s)	28	21	17

**Category 2 Races:** ORCi stability index of 110 or greater, or ISO 12217-2 Design Category A.

**Category 3 Races:** ORCi stability index of 103 or greater, or ISO 12217-2 Design Category or IRC Category A or B, or IRC SSS Base Value of 16 or greater, or SV of 10 or less subject to [B.5.1](#), or RMI of 1.4 or greater.

**Category 4 Races:** ORCi stability index of 103 or greater, or ISO 12217-2 Design Category or IRC Category A, B or C, or IRC SSS Base Value of 10 or greater, or SV of 10 or less subject to [B.5.1](#), or RMI of 1.4 or greater.



**Category 5 and 6 Races:** ORCi stability index of 103 or greater, or ISO 12217-2 Design Category or IRC Category A, B or C, or IRC SSS Base Value of 8 or greater, or SV of 14 or less subject to [B.5.1](#), or RMI of 1.1 or greater, or Horizontal Stability Factor.

### **B.3 SPECIFIC REQUIREMENTS**

**B.3.1** Apart from boats having only a centreboard or drop keel on the centreline of the hull, boats with movable or variable ballast shall additionally comply with Section [B.7](#).

#### **B.3.2 Verification**

A race committee may require the owner or charterer of a boat to confirm its resistance to capsize ability before accepting its entry.

**B.3.3** ORCi certificates used for the purposes of Appendix B need not be current provided that:

- (a) The certificate has been issued in the last 5 years;
- (b) For Category 2 races or above, the boat is still owned by the holder of the certificate;
- (c) The boat has not been modified; and
- (d) The current freeboard measurements have been confirmed as being consistent with the certificate.

### **B.4 ISO 12217-2 DESIGN CATEGORIES**

These shall be determined as specified in International Standard ISO 12217-2, Small craft – Stability and buoyancy assessment and categorisation – Part 2: Sailing boats of hull length greater than or equal to 6 m.

Notwithstanding the maximum length limit of 24 m in the ISO standard, when used in this Appendix it shall be applicable to longer boats.

#### **B.4.1 Stability**

##### **B.4.1.1 Boat Condition**

In the calculation of stability data:

- (a) Deck and other enclosed volume above the sheerline may be taken into account, in which case offsetting cockpit volume shall also be taken into account.
- (b) Mass shall be taken as Minimum Operating Mass as defined by ISO 12217-2, paragraph 3.5.3.

## **B.5 SCREENING PROCEDURE and RIGHTING MOMENT INDEX**

### **B.5.1 Screening Procedure**

A screening procedure has been established to determine those boats that are not required to be subjected to the practical test for RMI or calculation of the RMI (see [B.5.2](#)) and will be considered as complying with [3.04.1](#).

The Screening Procedure utilises three separate criteria, a Screening Value (SV), the distribution of ballast and the displacement of the boat.

An RMI test or calculation is required for:

- (a) (i) Category 3 and 4 races for any boat where the SV exceeds 10
- (ii) Category 5 and 6 races for any boat where the SV exceeds 14

Or

- (b) Any boat that carries more than 30% of its ballast internally

Or

- (c) Any boat with a displacement less than 1.5 tonnes.

A boat's SV is calculated using the formula:

$$SV = \frac{2.83 \times LH}{\text{Displacement}}$$

Where LH is in metres and displacement is in tonnes to 2 decimal places.

### **B.5.2 RMI Procedure**

Having followed the procedures in [B.5.1](#), the RMI for a boat requiring a test or calculation may be determined through:

- (a) A practical test.
- (b) Calculations provided by the designer or other appropriately qualified person using a recognised design package.

The practical test shall be at the owner's risk and cost, and no liability will be accepted by the club, the MYA or Australian Sailing or any of its members, officers or servants.

The **RMI** shall be calculated using the formula:

$$\text{RMI} = \frac{\text{TM}}{\text{W}}$$

Where:

**TM** is the Test Mass required to hold the mast in a horizontal athwartships position with the mass suspended at the upper point of I.

**W** is the theoretical equivalent mass at the upper point of I representing the total effect of the dynamic condition of a storm on a yacht whilst lying on its side, and is calculated using the formula:

$$W = 1.7 \times \frac{(2.79LB^2) + (0.05I^3) + (20.13L \times \text{FML})}{I + 0.5\text{FML}} \text{ Kilograms}$$

Where (in metres)

L= LH

B = Maximum Beam

FML= Freeboard at half LH

I = Height of Foretriangle from Deck

**For boats without a foresail the point at which the mainsail luff is 75% above the deck shall be taken as equivalent to the upper point of I.**

Any movable or variable ballast shall be placed in the position which minimises the righting moment.

## **B.6 HORIZONTAL STABILITY FACTOR (HSF)**

The **HSF** shall be the Test Mass (TM) required to hold the mast in a horizontal athwartships position when the mass is suspended from the hounds. It shall not be less than

$$T_M = \frac{(3.0LB^2 + 11.0L)}{IM} + 0.2H^2 \quad \text{Kilograms}$$

Where (in metres)

L = LH

B = Maximum Beam

IM = Sheer to Hounds

H = Mast length above step

**For boats without a foresail the point at which the mainsail luff is 75% above the deck shall be taken as equivalent to the upper point of IM.**

The term  $0.2H^2$  may be omitted if the mast is effectively watertight and buoyant.

During the practical test all gear shall be stowed normally, outboard motors shall be in the required position, the keel locked down and no sails shall be hoisted.

Determination of the HSF shall be at the owner's risk and cost, and no liability will be accepted by the Club, the MYA or Australian Sailing or any of its members, officers or servants.

## **B.7 BOATS WITH MOVABLE OR VARIABLE BALLAST**

### **B.7.1 Use of ORCi**

#### **B.7.1.1 General Standards**

Boats with movable and/or variable ballast shall comply with the following minimum values of Ballast Leeward Recovery Index (BLR Index)

<b>Race category</b>	<b>1,2</b>	<b>3</b>	<b>4 -6</b>
BLR Index	0.9		
BLR Index		0.8	
BLR Index			0.7

### **B.7.2 Use of ISO**

**B.7.2.1 Boat Condition**

In the calculation of stability data mass shall be taken as Minimum Operating Mass as defined by ISO 12217-2, paragraph 3.5.3.

**B.7.2.2 General Standards**

In the assessment of ISO category for yachts fitted with movable and/or variable ballast, ISO 12217-2, paragraph 6.1.4 (b) shall not apply. Boats shall comply with paragraphs 6.2.3, 6.3.1 and 6.4. Calculations shall be for the ballast condition that results in the most adverse result when considering each individual stability requirement. ISO 12217-2 Annex C, paragraph C.3.3, first sentence, the word “may” is replaced with “shall”. ISO 12217-2 Annex C, paragraph C.3.4 shall not be used in the calculation of righting lever.

**B.7.2.3 Knockdown Recovery**

Boats with movable and/or variable ballast shall comply with the following minimum values of Knockdown Recovery Factor (FKR) calculated in accordance with ISO 12217-2 paragraph 6.4.4 with the modification that the reference to ISO 8666 paragraph 5.5.2 changed to incorporate actual mainsail area and centre of effort. The lesser of  $FKR_{90}$  and  $FKR_{-90}$  shall be used:

<b>Race category</b>	<b>1,2</b>	<b>3</b>	<b>4 -6</b>
FKR	0.9		
FKR		0.8	
FKR			0.7

**B.7.3 Use of RMI****B.7.3.1 General Standards**

In the assessment of RMI for yachts fitted with movable and/or variable ballast, tests or calculations shall be made for the ballast condition that results in the most adverse result.

**B.7.3.2 Knockdown Recovery**

Boats with movable and/or variable ballast shall comply with the following minimum values RMI tested or calculated in accordance with section [B.5](#):

<b>SR Category</b>	<b>3, 4</b>	<b>5 and 6</b>
--------------------	-------------	----------------

RMI	1.6
RMI	1.4 for boats greater than 8 m LH 1.55 for boats 8 m LH or less

**B.7.4 Use of HSF**

**B.7.4.1 General Standards**

In the assessment of HSF for yachts fitted with movable and/or variable ballast, tests or calculations shall be made for the ballast condition that results in the most adverse result.

**B.7.4.2 Knockdown Recovery**

Boats with moveable or variable ballast shall comply with the following minimum values HSF when tested in accordance with section [B.6](#):

HSF times	1.3 for boats greater than 8 m LH 1.5 for boats 8 m LH or less
-----------	---

### APPENDIX C TO PART 1

#### MODEL KEEL AND RUDDER INSPECTION PROCEDURE

Structural Inspection of a boat shall be completed by a qualified person both internally (may be in the water) and externally (out of the water). The purpose of this inspection is to identify and report to the Owner the condition of the keel and keel structure observed during this inspection. It is the responsibility of the Owner to undertake any repairs.

Consult the Owners' Manual for the specific boat, steering system, and type of keel (e.g. fin, lifting, swinging, full length). Inspect in detail any high-load areas: keel attachment, keel floor, steering systems, rudder(s). Pay special attention to prior repairs, especially following groundings.

Internal Inspection: Check backing plates, bolting arrangements, sump area and keel floors for any signs of cracking, weakening, or de-laminated tabbing. Lead or lead alloy keels may require tightening of bolts to ISO standards due to lead creeping. Inspect keel bolt nuts for corrosion. Check bolt holes for "ovalling." Visually inspect for possible de-bonding of the supporting structure.

External Inspection: Check there are no signs of stress cracks (not gelcoat cracks) around the keel attachments to hull, or movement or opening around the keel/hull interface which may allow water ingress and consequent keel bolt crevice corrosion. If in doubt, sand back bottom paint/gel coat to identify depth of crack. Check keel tip deflection to ensure immediate return and no internal concomitant movement in the keel floor. Visually check high stress regions, particularly around the forward and aft hull attachment areas of the keel, for signs of paint or gelcoat cracking or large, deep blisters, which can indicate separation and structural weakness.

Rudder/Steering system: Check bearing area for any damage/stress cracks; check rudder shaft and blade integrity, especially at any shaft joins and at upper connections to hull/deck. Undertake a tip deflection test to identify any excessive movement. If applicable, check rudder straps and gudgeons for corrosion or cracking.

Lifting and swing keels: In addition to above, check there are no significant stress cracks in structure around pins supporting the keel. Check for extensive corrosion on pins, cylinders and supporting metal structure.



## SECTION 8 – ADVISORY APPENDICES

### ADVISORY APPENDIX D to Part 1

#### MAN OVERBOARD - QUICK STOP AND THE LIFE SLING (OR SEATTLE SLING)

When a crew member goes over the side recovery time is of the essence. In an effort to come up with a recovery system that is simple and lightning quick, the US Yacht Racing Union Safety at Sea Committee, the US Naval Academy Sailing Squadron, the Cruising Club of America Technical Committee and the Sailing Foundation of Seattle, Washington, joined forces to conduct extensive research and sea trials. The result of their collaboration is the "Quick Stop" method of man overboard recovery.

The hallmark of this method is the immediate reduction of boat speed by turning to windward and then manoeuvring slowly, remaining near the victim.

In most cases, this is better than reaching off, then gybing or tacking and returning on a reciprocal course.

#### QUICK STOP

1. **Shout "man overboard"** and detail a crew member to spot and point to **the victim's position** in the water. The spotter should not take his eyes off the victim (see Figure 1).
2. **Provide immediate flotation.** Throw buoyant objects such as cockpit cushions, life rings and so on. These objects may not only come to the aid of the victim, but will "litter the water" where he went overboard and help your spotter to keep him in view. Deployment of the pole and flag (dan buoy) requires too much time. The pole is saved to "put on top" of the victim in case the initial manoeuvre is unsuccessful.
3. **Bring boat head-to-wind** and beyond (see Figure 1)
4. **Allow headsail to back** and further slow the boat.
5. **Keep turning with headsail backed** until wind is abaft the beam.
6. **Head on beam-to-broad reach course** for two or three lengths then go nearly dead downwind.

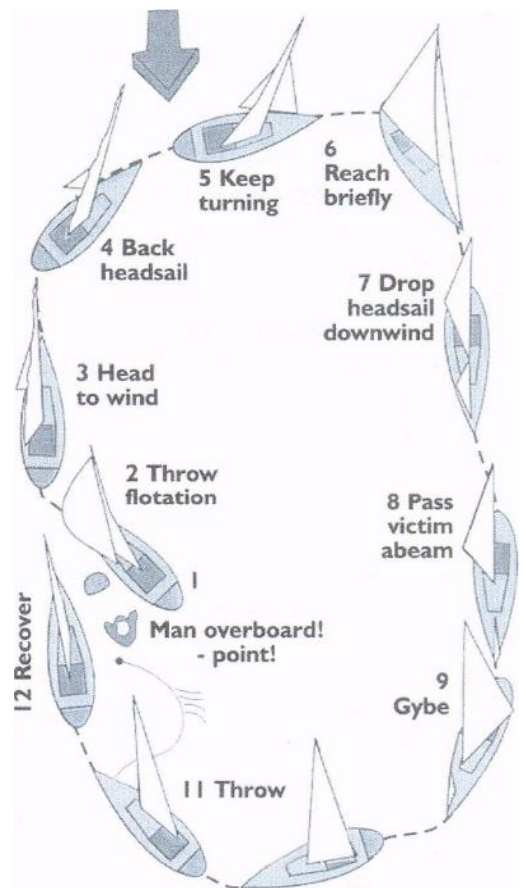

7. **Drop the headsail** while keeping the mainsail centred (or nearly so). The jib sheets are not slacked, even during the dousing manoeuvre, to keep them inside the lifelines.
8. **Hold the downward course** until victim is abaft the beam.
9. **Gybe.**
10. **Approach the victim** on a course of **approximately** 45 degrees to 60 degrees off the wind.
11. **Establish contact** with the victim with heaving line or other device.  
The Naval Academy uses a "throwing sock" containing 75 feet of light floating line and a bag that can be thrown into the wind because the line is kept inside the bag and trails out as it sails to the victim.
12. **Effect recovery** over the windward side.

### **Quick Stop Under Spinnaker**

The same procedure is used to accommodate a spinnaker. Follow the preceding instructions. As the boat comes head-to-wind and the pole is eased to the head stay, the spinnaker halyard is lowered and the sail is gathered on the fore deck. The turn is continued through the tack and the approach phase commences.

### **Quick Stop in Yawls and Ketches**

Experiment with your mizzen sail. During sea trials, it was found best to drop the mizzen as soon as possible during the early phases of Quick Stop.

### **Quick Stop Using Engine**

Use of the engine is not essential, although it is advisable to have it in during Quick Stop in case it is needed in the final approach. Check first for trailing lines!

### SHORTHANDED CREWS

When there are only two people sailing together and a man-overboard accident occurs, the remaining crew member may have difficulty in handling the recovery alone. If the victim has sustained injuries, getting him back aboard may be almost impossible. The Quick-Stop method is simple to effect by a singlehander, with only one alteration to the procedure: the addition of the “Lifesling”, a floating horsecollar device that doubles as a hoisting sling. The Lifesling is attached to the boat by a length of floating line three or four times the boat’s length.

When a crew member falls overboard the scenario should proceed as follows:

1. A cushion or other flotation is thrown while the boat is brought IMMEDIATELY head-to-wind, slowed and stopped.

*Reproduced by kind permission of US Sailing.*

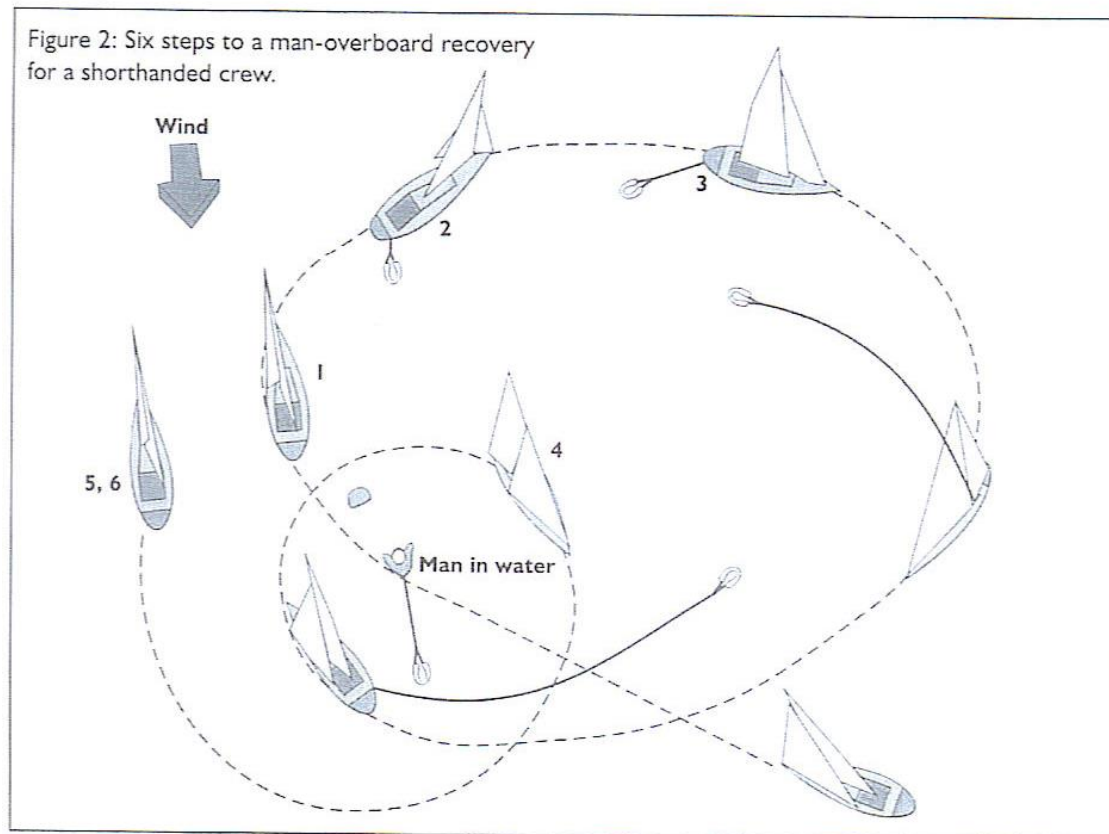

2. The Lifesling is deployed by opening the bag on the stern pulpit and dropping the sling into the water. It will trail astern and draw out the line.

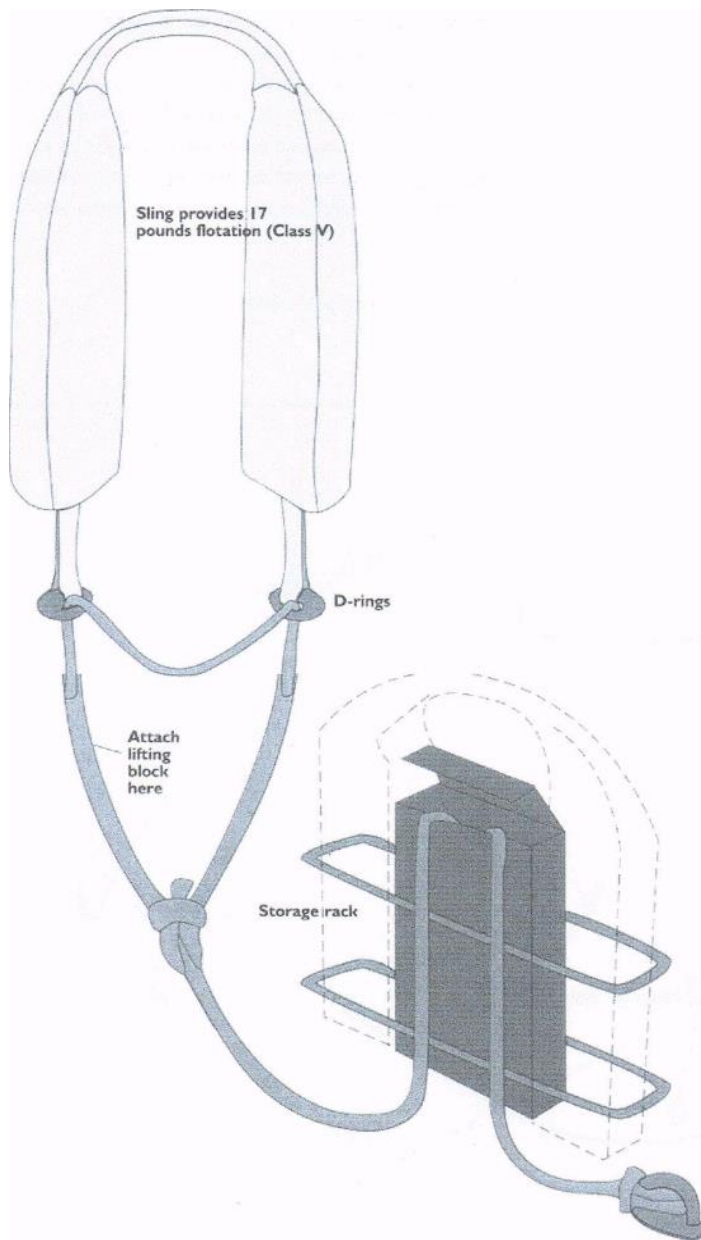

3. Once deployed, the boat is sailed in a wide circle around the victim with the line and sling trailing. The jib is allowed to back from head-to-wind, increasing the rate of turn.

4. Contact is established with the victim by the line and sling being drawn inward by the boat's circling motion. The victim places the sling over his head and under his arms.

5. Upon contact, the boat is put head-to-wind again, the headsail is dropped to the deck and the main is doused.

6. As the boat drifts slowly backward, the crew begins pulling the sling and the victim to the boat. If necessary, a cockpit winch can be used to assist in this phase, which should continue until the victim is alongside and pulled up tightly until he is suspended in the sling (so that he will not drop out). But see following page for advice on a horizontal lift, which is preferable when there is a choice.

## PARBUCKLE DEVICE

This is an alternative to the hoisting rig. A patent version is known as the Tri-buckle. Another version is rectangular, like a climbing net. The net, or triangle of strong porous material, is clipped to the toe rail, the triangle top or net extremity clipped to a halyard extension. The casualty is manoeuvred or dragged alongside into the triangle or net then rolled onto the deck by hoisting the halyard.

Hypothermic aftershock may be minimised by this method which keeps the casualty essentially horizontal.

Lift

## THE HOISTING RIG

### **NOTE:**

Since the hoisting rig was developed, more evidence has emphasised the value in keeping a victim horizontal particularly after long or hypothermic immersion. A

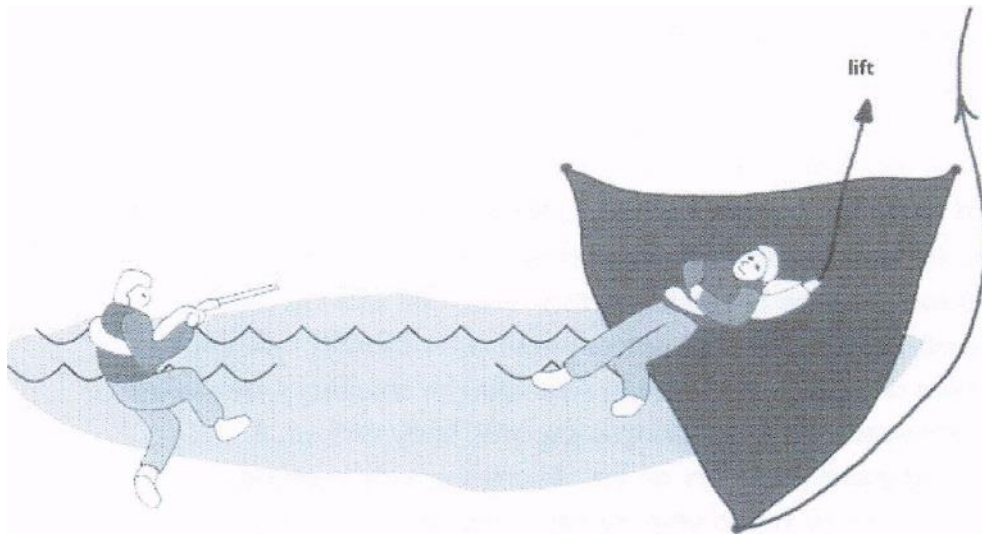

parbuckle or horizontal lift is highly desirable (see below).

1. With the floating tether line, haul the victim alongside, preferably on the windward side, from amidships to the quarter, wherever there are available cleats and winches.
2. Pull up on the tether line (with winch assistance, if necessary) to get the victim's head and shoulders out of the water and cleat it. The victim is now safe.
3. Attach a three-part or four-part tackle to the main halyard, haul it up to a predetermined point, about 10 feet above the deck or high enough so that the victim can be hoisted up and over the lifelines. Cleat off the halyard.
4. Attach the lower end of the tackle to the (previously sized) loop in the tether line that passes through the D-rings of the sling.
5. Reeve the running end of the tackle through a sheet block or snatch block on deck and put it on a cockpit winch. Hoist the victim aboard by winching it on the running end of the tackle



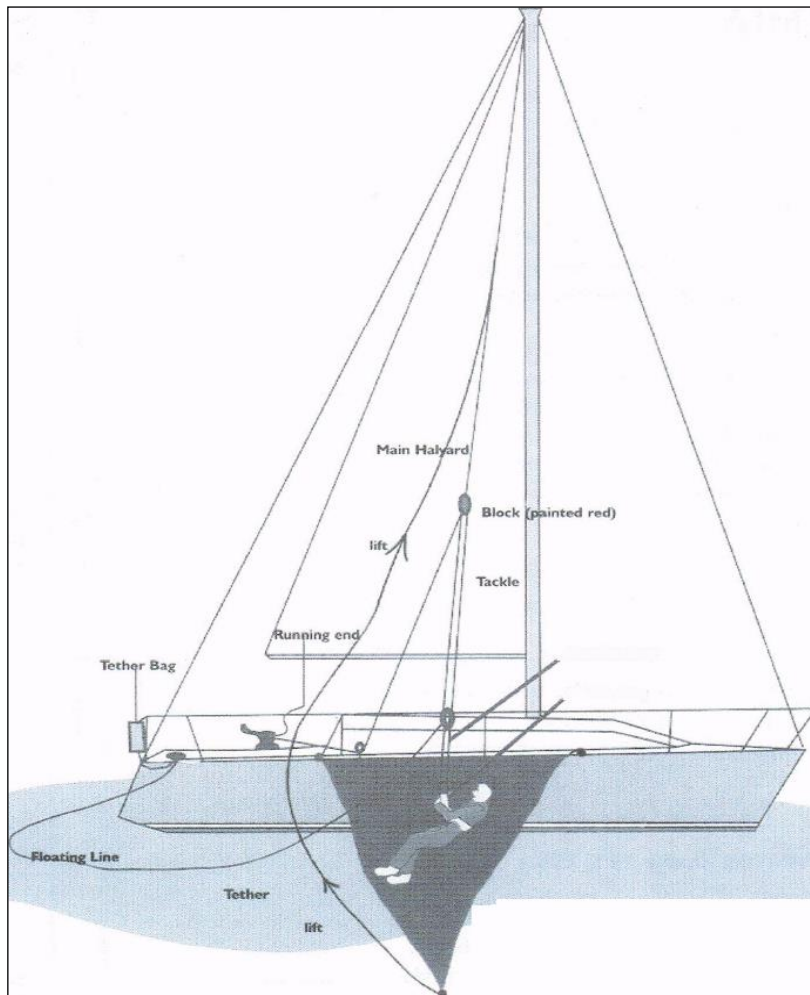

### ADVISORY APPENDIX E to Part 1

#### HYPOTHERMIA

##### WHAT IS IT?

A condition in which exposure to cold air and/or water lowers body core temperature. Death can result from too low a brain and heart temperature.

##### WHY BE CONCERNED?

Hypothermia, even mild cases, decreases crew efficiency and increases risk of costly accidents. ***Proper planning against hypothermia can give a winning competitive edge.***

##### PREVENTION

- Wear warm clothing and a lifejacket/harness. Have proper foul-weather kit for all crew. Dry suits are excellent. Insulate all areas of the body, especially the high heat-loss areas: head, neck, armpits, sides of chest and groin. Keep warm and dry, but avoid sweating; wear layered clothes.
- Rotate watch frequently.
- Get plenty of rest, prevent fatigue.
- Eat and drink normally, *no alcohol*.
- Prevent dehydration; watch urine colour (drink more if colour becomes more intense).
- Avoid seasickness.
- Take into account special medical problems of crew members.
- Regularly train crew in Man Overboard recovery.
- Have two or more crew trained in CPR (Cardio-pulmonary resuscitation).

## **SURVIVAL IN COLD WATER (under 75 °F, 25 °C)**

- **If boat is in trouble**, put on dry or survival suits if carried. Radio for help; give position, number of crew, injuries, boat description. Make visual distress signals. Stay below if possible. Remain aboard until sinking is inevitable.
- **If going overboard**, launch life raft and EPIRB (Emergency Position Indicating Radio Beacon). Take grab bag, visual distress signals and waterproof hand-held VHF. Get into raft, stay out of water as water conducts heat out of the body 20 times faster than air. Remain near boat if practicable.
- **If in the water**, crew should stay together near the boat. This makes everyone easier to find, helps morale. Enter life raft; keep dry suit or survival suit on if worn.
- **If not wearing dry suit or survival suit**, make sure you wear a lifejacket, keep clothes and shoes on for some insulation and flotation. Keep hat on to protect head. Get all or as much of body out of water as soon as possible - into raft or swamped boat or onto flotsam. Avoid swimming or treading water, which increases heat loss. Minimise exposed body surface. A splashguard accessory on the lifejacket greatly improves resistance to swallowing seawater and also accommodates involuntary "gasping" when plunged into cold water.

### **WARNING**

- First aid for severe and critical hypothermia is to add heat to stabilise temperature only. Rapid re-warming, such as a hot shower or bath, may be fatal; it will, at least, cause complications. Allow body to re-warm itself slowly.
- Body core temperature lags behind skin temperature during re-warming. Keep victim protected for extended period after apparent full recovery or medical help arrives. *Many hours are required for full return to normal temperature even though victim says he has recovered.*
- Always assume hypothermia is present in all man overboard situations in which victim has been exposed for more than 10-15 minutes
- Victims may also be suffering from near drowning, thus needing oxygen. Observe for vomiting.
- In a helicopter rescue, protect victim - including the head - from rotor blast wind chill.

## **HYPOTHERMIA FIRST AID**

### **ALL CASES**

- Keep victim horizontal
- Move victim to dry, shelter and warmth
- Allow to urinate from horizontal position



- Handle gently
- Remove wet clothes - cut off if necessary
- Apply mild heat (comfortable to your skin) to head, neck, chest and groin - use hot water bottles, warm moist towels
- Cover with blankets or sleeping bag; insulate from cold — including head and neck
- Report to doctor by radio

### **MILD CASES**

- Primary task is to prevent further heat loss and allow body to re-warm itself
- Give warm, sweet drinks — *no alcohol - no caffeine*
- Apply mild heat source to stabilise temperature and/or
- Re-heat to point of perspiring
- Keep victim warm and horizontal for several hours

### **MODERATE CASES**

- Same as above
- Offer sips of warm liquid only if victim is fully conscious and able to swallow without difficulty — *no alcohol — no caffeine*
- Have victim checked by doctor

### **SEVERE CASES**

- Obtain medical advice as soon as possible using your radio
- Assist victim, but avoid jarring him — rough handling may cause cardiac arrest or ventricular fibrillation of heart
- No food or drink
- Observe for vomiting and be prepared to clear airway
- *Ignore pleas of "Leave me alone, I'm OK" victim is in serious trouble — keep continuous watch over victim*
- Lay victim down in bunk, wedge in place, elevate feet, keep immobile; no exercise
- Apply external mild heat to head, neck, chest and groin — keep temperature from dropping, but avoid too rapid a temperature rise

### **CRITICAL CASES**

- *Always assume the patient is revivable — hypothermic victims may look dead but don't give up - pulse very difficult to feel, breathing may have stopped*
- Handle with extreme care
- Tilt the head back to open the airway — look, listen and feel for breathing and pulse for *one to two full minutes*
- If there is any breathing or pulse, no matter how faint or slow, do not give CPR, but keep a close watch on vital sign changes

- Stabilise temperature with available heat sources, such as naked chest to back warming by other crew member (leave legs alone)
- If no breathing or pulse for one or two minutes, *begin CPR immediately. Do not give up until victim is thoroughly warm — alive or dead.*
- *Medical help is imperative — hospitalisation needed*

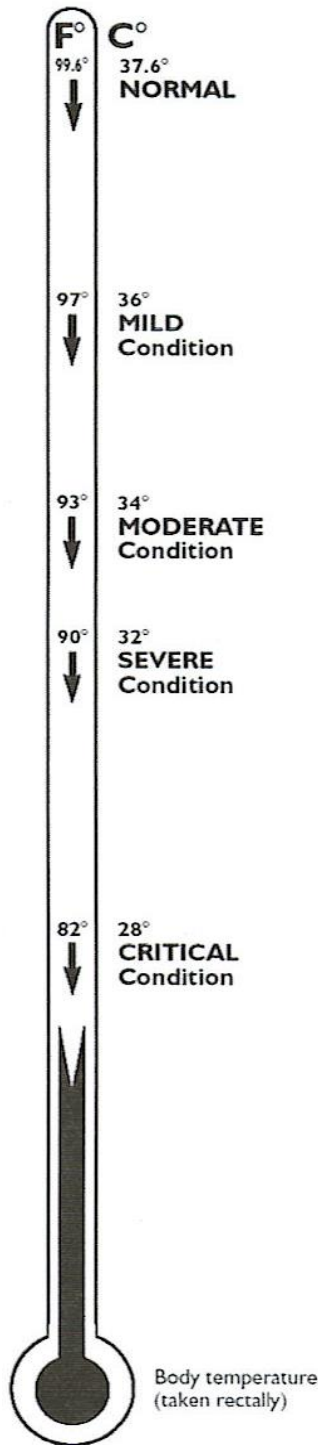

**RANGES OF HYPOTHERMIA SYMPTOMS**

**MILD CONDITIONS (97-93°F, 36-34°C)**

- Shivering, cold hands and feet
- Still alert and able to help self
- Numbness in limbs, loss of dexterity, clumsiness
- Pain from cold

**MODERATE CONDITIONS (93-90°F, 34-32°C)**

- Same as above
- Confusion, loss of time estimation and reasoning power

**SEVERE CONDITIONS (90-82°F, 32-28°C)**

- Shivering decreases or stops
- Further loss of reasoning and recall, confusion, abnormal behaviour.
- Victim appears drunk; very clumsy, slurs speech, denies problem and may resist help
- Unable to help themselves
- Victim semiconscious to unconscious
- Muscular rigidity increasing

**CRITICAL CONDITIONS (82°F, 28°C and below)**

- Unconscious, may look dead
- Little or no apparent breathing
- Pulse slow and weak, or no pulse found
- Skin cold, may be bluish-grey colour
- Very rigid

Note: Most physical symptoms vary with each individual and may be unreliable indicators of core body temperature. Only a low temperature rectal thermometer gives reliable core temperature (the mouth cools too rapidly). In general, as body temperature falls, symptoms will increase.

*Reproduced by kind permission of US Sailing, Box 209, Newport, RI 02840, USA and Richard Clifford.*

### ADVISORY APPENDIX F to Part 1

#### DROGUES AND SEA ANCHORS

##### TERMINOLOGY

The term "*drogue*" generally means a device dragged from the stern of a vessel which continues to make steerage way through the water but at reduced speed. The term "*sea anchor*" generally means a device streamed from the bows of a vessel practically halted in the water by the action of the sea anchor.

##### LIFERAFTS

Every liferaft has a sea anchor supplied as part of its equipment. A sea anchor is critical to the safe use of a liferaft and dramatically reduces the chance of liferaft capsize. Its secondary function is to limit drift. A spare sea anchor may be carried in a grab bag. Sea anchors in liferafts should comply with ISO 17339 and the opportunity should be taken at service intervals to ensure this.

##### DROGUES ON YACHTS

A number of research programmes have been conducted including one for the RORC by the Southampton University Wolfson Unit. In tests drogue deployment repeatedly prevented typical yacht forms from being slewed sideways and rolled in heavy breaking seas.

Deployment of a drogue over the stern means that heavy water will break over that part of the yacht, so all openings must be properly secured shut.

A "series-drogue" invented by Donald Jordan has the ability to continue to provide drag even if part of the device is "surfing" under a wave crest

## SEA ANCHORS ON YACHTS

The most common form of sea anchor for yachts is the "parachute" anchor developed from aviation parachutes. Specialist manufacturers have accumulated much data to demonstrate the effectiveness of the device which can enable a vessel to take seas bows-on, reduce drift to the order of one knot, and resist capsize.

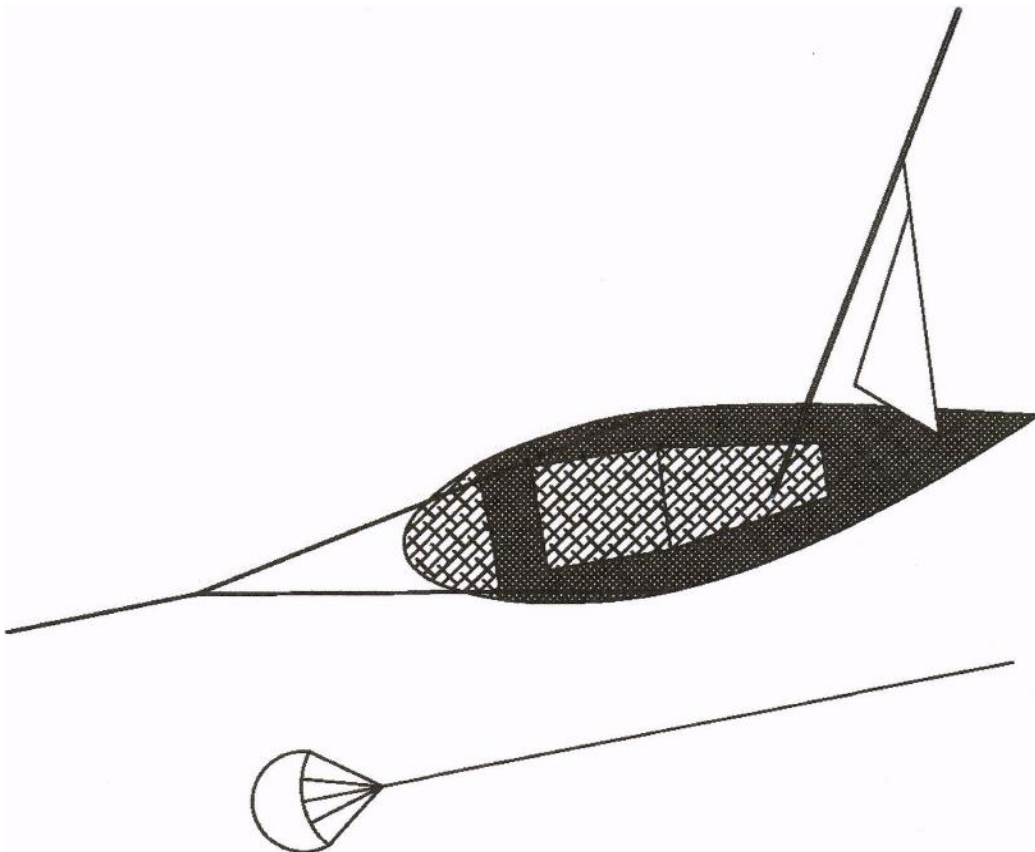

Sketch shows small parachute anchor used as drogue. Bridle lines led to port and starboard main winches can provide emergency steering. *Product obtained from a specialist supplier is recommended.*

## WHERE DOES IT HURT ?

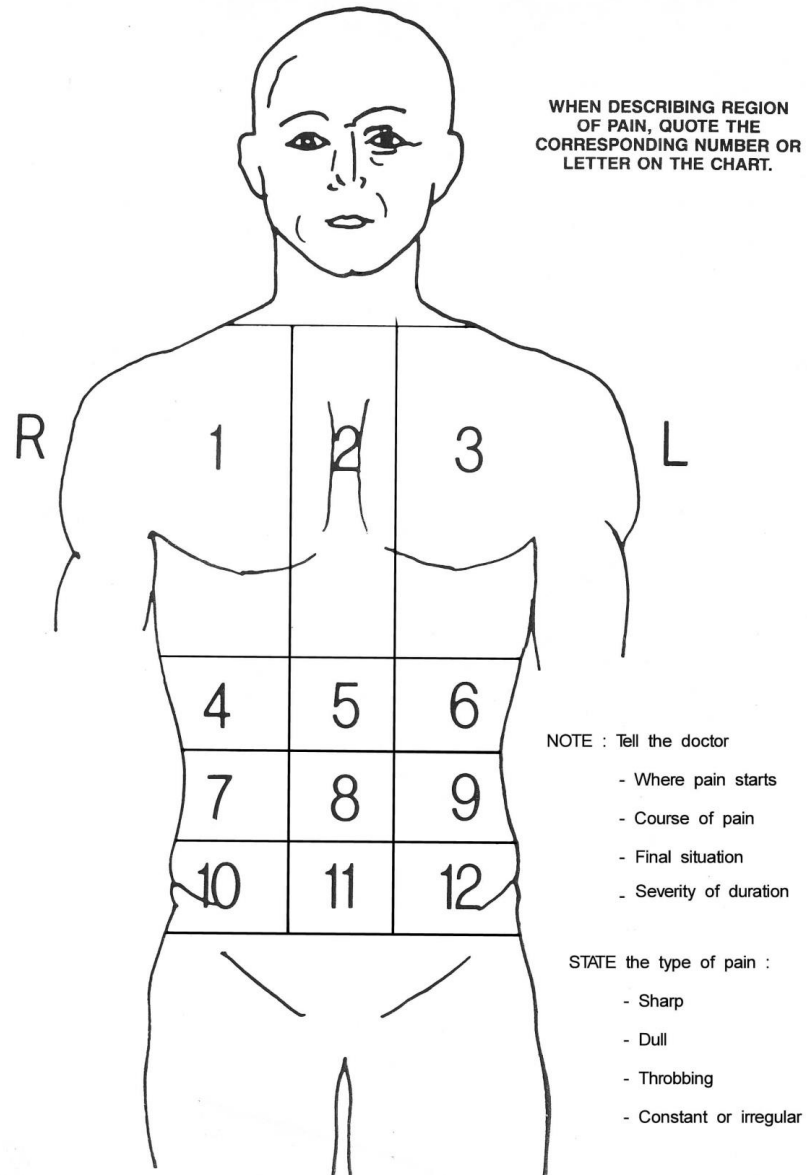
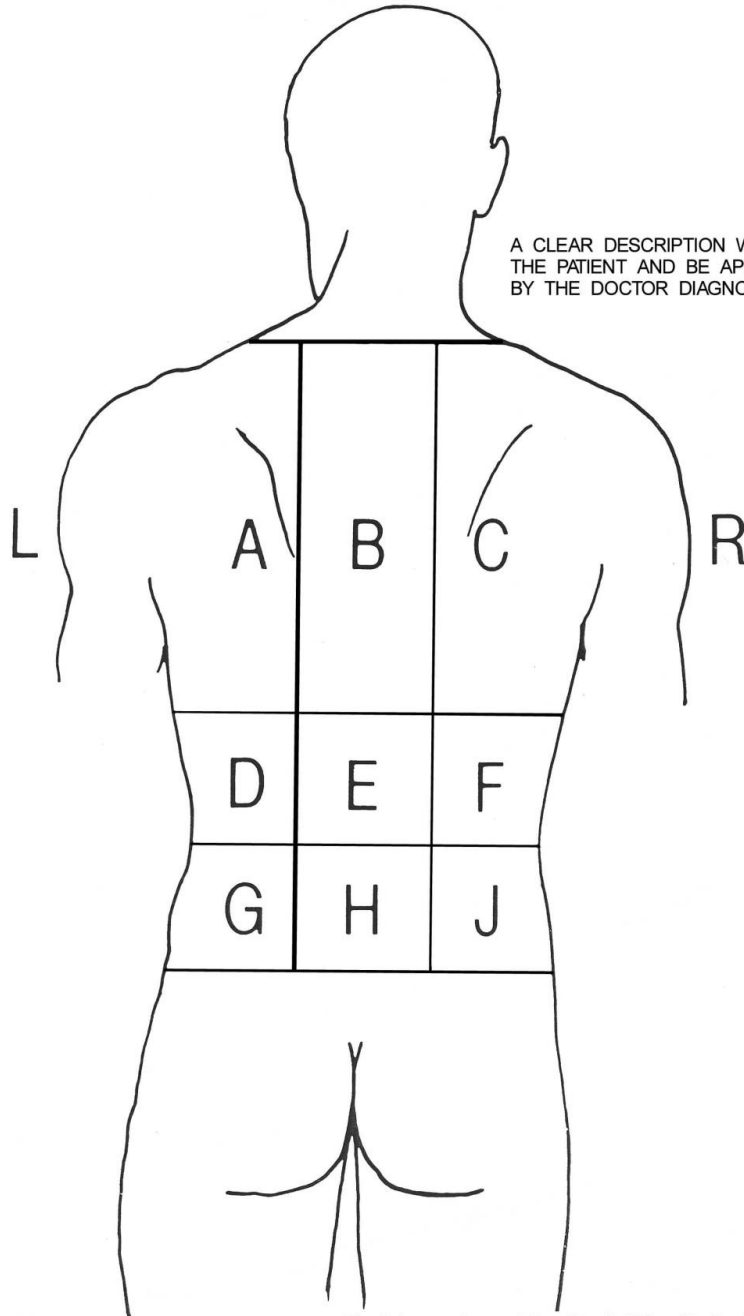

Chart by courtesy of the Royal Flying Doctor Service of Australia

A description of injury or illness must often be given to a doctor who cannot see the patient.



A CLEAR DESCRIPTION WILL HELP THE PATIENT AND BE APPRECIATED BY THE DOCTOR DIAGNOSING THE CASE

Chart by courtesy of the Royal Flying Doctor Service of Australia